

JKS[®]

Installation Instructions

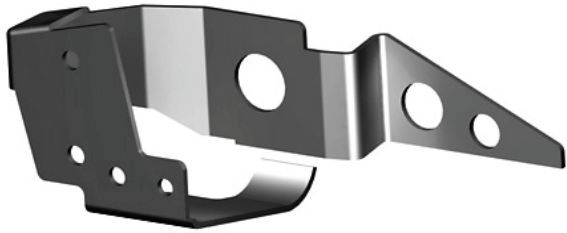

Product: **Front Trackbar Brace**

Part Number: **PN OGS161**

Application: **Jeep Wrangler JK, 2007+ (front)**

Welcome

CONGRATULATIONS on purchasing a new Front Trackbar Brace from JKS Manufacturing. We are committed to providing you with the best products available and your satisfaction is our first priority.

PLEASE READ these Installation Instructions carefully, and save them for future reference, as they contain important installation and maintenance information.

Important

INSTALLATION REQUIRES WELDING by a qualified welder or metal fabricator.

JKS ADJUSTABLE TRACKBAR IS REQUIRED if existing track bar interferes with steering damper.

Tools Required

- Hydraulic Floor Jack & Jack Stands
- Metric/Standard Socket Wrench Set
- Black Felt Tip Marker (or equivalent)
- Torque Wrench
- Die Grinder with Sanding Wheel (or equivalent tool for removing paint)
- Welding Equipment
- Weldable Corrosion Resistant Coating, 3M[®] PN 05917 (or equivalent)
- Satin Black Spray Paint
- Anti-Seize Lubricant *
- Factory Service Manual (recommended)

** Indicates tool that may not be necessary for every installation. Thoroughly read instructions in advance to determine which tools will be required for your application.*

Parts



	DESCRIPTION	QTY
A	Front Trackbar Brace	1
B	Steel Sleeve	1
C	M12 x 70mm GR5 Bolt	2
D	M12 Flat Washer	3
E	M12 Nylock Nut	1

Installation

- **1. REMOVE FRONT TRACK BAR**
 - Raise and support vehicle chassis with jack stands positioned behind the front lower suspension arm brackets.
 - Raise and support front axle housing with a hydraulic jack just enough to relieve any tension from the track bar mounting bolts.
 - Remove front track bar mounting hardware from axle and chassis brackets per the factory service manual instructions for your vehicle. Retain original hardware and remove front track bar from vehicle.
 - Remove steering damper mounting hardware from the axle housing and tie rod. Remove steering damper from vehicle and retain original hardware.
 - Prime entire surface of Trackbar Brace with 3M[®] Weldable Corrosion Resistant Coating (or equivalent – must be weldable).
- **2. PREPARE AXLE FOR WELDING**
 - To ensure a proper fit, clean any dirt, debris or grease from surface of factory track bar bracket.

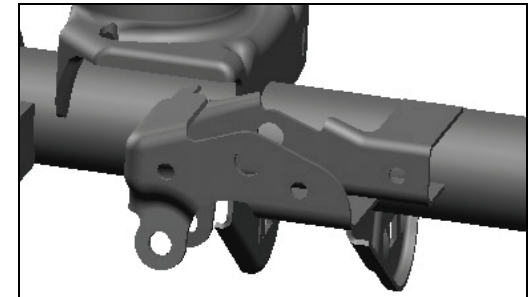

- Slide Trackbar Brace over factory track bar bracket as illustrated. **HINT:** Trackbar Brace is designed to provide a snug fit and may require some persuasion to maneuver into position.

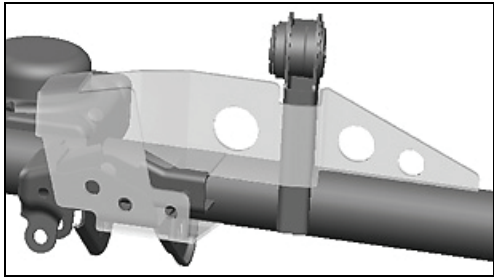

- With Trackbar Brace in position, insert one M12 x 70mm Bolt (C) into original mounting hole as illustrated below. Secure bolt with original flag nut and temporarily tighten to hold the brace securely to the factory bracket.

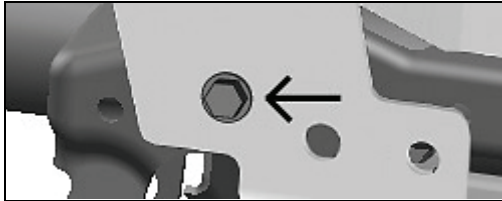

- To prepare for welding, clearly mark the weld locations directly on the axle housing as indicated in the following two illustrations. **HINT:** A felt tip marker is useful for marking locations to be welded.

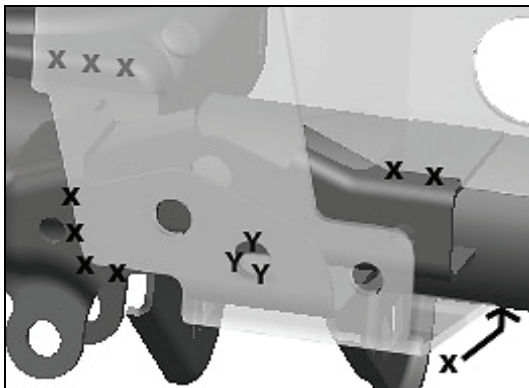

HINT: Be sure to include area on lower spring mount where it makes contact with Trackbar Brace. Also include back side of axle tube where Trackbar Brace wraps underneath.

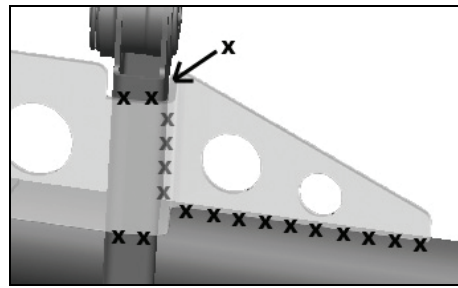

HINT: Include area on vertical upper control arm mount.

- Remove Trackbar Brace and thoroughly clean locations on axle housing marked by an "X" or a "Y". **HINT:** A die grinder with sanding wheel or similar tool is useful for removing paint from axle housing.

IMPORTANT: The Trackbar Brace must be welded to bare metal. Remove any paint, rust or other contaminants before welding.

3. WELD TRACKBAR BRACE TO AXLE HOUSING

- With all indicated surfaces prepped for welding, reposition Trackbar Brace on axle housing. Reinstall the M12 x 70mm Bolt (C) and original flag nut to secure the brace in position.
- Tack weld Trackbar Brace to axle in the exact sequence indicated below.

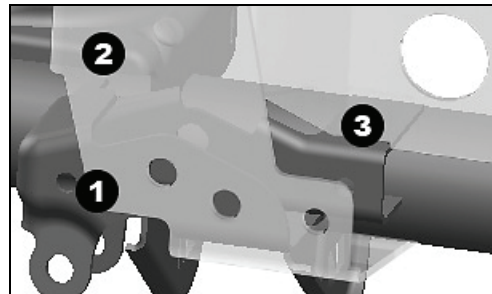

- 1 Tack weld front of Trackbar Brace to factory track bar bracket.
- 2 Tack weld back of Trackbar Brace to lower coil spring mount.
- 3 While pushing Trackbar Brace against vertical upper control arm mount to minimize gap at location 4, tack weld front of brace to factory track bar bracket.

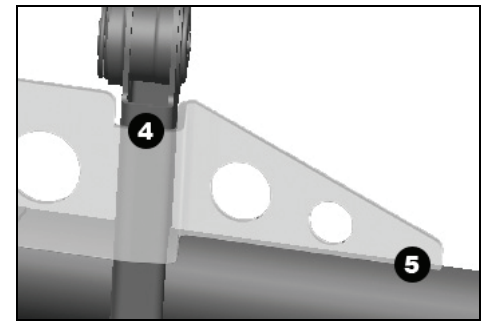

- 4 While pushing Trackbar Brace against axle tube to minimize gap at location 4, tack weld front of brace to vertical upper control arm mount.
- 5 Finally, tack weld end of Trackbar Brace to axle tube.

- Next, fillet weld Trackbar Brace to axle housing at all locations indicated by an "X" in step 2. **Do not weld location indicated by "Y" if you plan to install optional Steering Stabilizer Mount PN OGS921.**



IMPORTANT: Avoid overheating axle tube and rubber bushing in vertical upper control arm mount by welding a small section and allowing the surface to cool off regularly.

- To install optional weld-on Steering Stabilizer Mount PN OGS921 (sold separately), position base of stabilizer mount in middle hole of Trackbar Brace as illustrated below. Weld base of stabilizer mount to Trackbar Brace.



- If you are not installing a new steering stabilizer mount, plug weld Trackbar Brace to factory trackbar mounting bracket at location indicated by a “Y” in step 2.



- Once all welding is complete, spray paint entire Trackbar Brace and any bare metal on axle housing to prevent corrosion. All exposed metal must be completely covered.

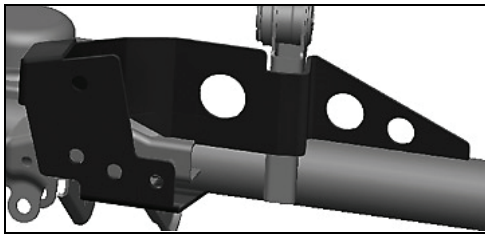

❑ 4. REINSTALL FRONT TRACK BAR

- Apply anti-seize lubricant to bolt threads of track bar mounting hardware.
- Insert axle end of track bar into reinforced axle bracket first and loosely install M12 x 70mm Bolt (C), M12 Flat Washer (D) and original flag nut. **HINT:** Use the lower mounting hole if steering linkage is in the factory position...

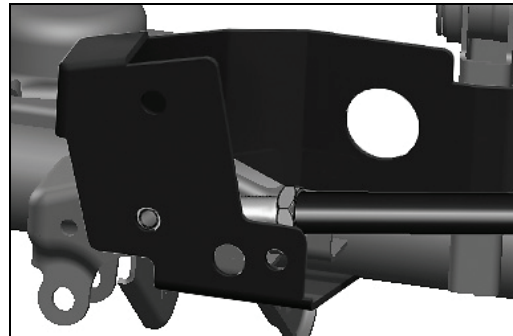

...or use the upper mounting hole if vehicle has a “drag link flip” or high-steering conversion. When track bar is installed in the upper hole, supplied steel sleeve must be installed in the lower hole using hardware provided.

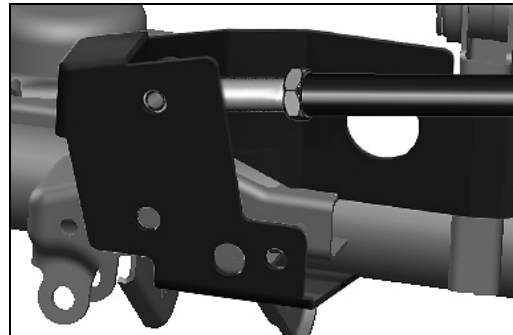

- Mount chassis end of track bar and loosely install original mounting hardware. **Vehicle must be on level ground with coil springs supporting the full vehicle weight before mounting hardware is tightened.**
- Using a torque wrench, tighten mounting hardware at both ends of track bar to 125 ft-lbs.

- Insert Steel Sleeve (B) into unused track bar mounting hole. Secure sleeve by installing remaining M12 x 70mm Bolt (C), M12 Flat Washer (D) and M12 Nylock Nut (E).
- Using a torque wrench, tighten Steel Sleeve (B) mounting bolt to 125 ft-lbs.

❑ 5. REINSTALL STEERING DAMPER

If you chose to relocate the axle end of your steering damper by installing an aftermarket mount (such as the JKS Steering Stabilizer Mount PN OGS921 previously mentioned), then the factory mounting position on the axle housing will no longer be used.

- Secure body end of steering damper to appropriate mounting point on axle housing. **It is the responsibility of the installer to ensure the steering damper is mounted properly to the axle housing, and is the appropriate size for the mounting position used.**
- If you relocated the axle end of steering damper, remove the U-bolts that secure the factory steering damper bracket to the tie rod and spin the bracket 180 degrees so the mounting stud is located on passenger side of U-bolts. **If axle end of steering damper remains in the factory position, disregard this step as well as the following step.**
- Reinstall the U-bolts and finger tighten hardware so that factory steering damper bracket can slide freely on tie rod. Determine the appropriate mounting position and tighten the original hardware to factory torque specifications.
- Mount shaft end of steering damper to bracket on tie rod using original mounting hardware.
- Tighten hardware to factory torque specifications.
- If no longer being used, you may remove original steering damper mounting tabs from axle housing for improved clearance.

© 2011 JKS Manufacturing, Inc & Aftermarketing, LLC
Revision Date 1/4/2011