



INSTALLATION INSTRUCTIONS

Product: J-Link Lower Control Arms

Part Number: JKS1651

Applications: Wrangler TJ, 1997-06 (front or rear)

Gr. Cherokee WJ, 1999-04 (front or rear)*

Gr. Cherokee ZJ, 1993-98 (front or rear)

Cherokee XJ, 1984-01 (front only)

Comanche MJ, 1986-92 (front only)

517-278-1226 • jks@sporttruckusainc.com • www.jksmfg.com
491 W. Garfield Avenue, Coldwater, MI 49036

*WJ models require JKS 6109



Welcome

CONGRATULATIONS on purchasing a set of J-Link Lower Control Arms from JKS Manufacturing. We are committed to providing you with the best products available and your satisfaction is our first priority.

PLEASE READ these Installation Instructions carefully, and save them for future reference, as they contain important installation and maintenance information.

Important

COMPATIBLE WITH original 4-link suspension configuration and vehicle ride height up to 4.0"

REFER TO FACTORY SERVICE MANUAL for information and procedures not covered in these instructions.

Tools Required

- Metric/Standard Socket Wrench Set
- Torque Wrench
- Tape Measure
- Anti-Seize Lubrication
- Hydraulic Floor Jack & Jack Stands

** Asterisk denotes tools that are not required for some applications. Thoroughly read instructions first to determine which tools will be required for your application.*

Pre-Installation Note

GRAND CHEROKEE WJ NOTE

IMPORTANT NOTE REGARDING CONTROL ARM SPACERS FOR GRAND CHEROKEE WJ MODELS

The factory suspension arm brackets on the chassis and axle are wider than the control arm bushings. Therefore, it is necessary to insert spacer washers between the bracket and bushing to fill this void as illustrated.

Both front and rear control arms require the same spacers. Enough spacers for 1 set of arms is included in JKS6109.

The axle mount requires one 1/4" thick washer on each side of the control arm.

The frame mount requires one 1/8" thick spacer on each side for the control arm.

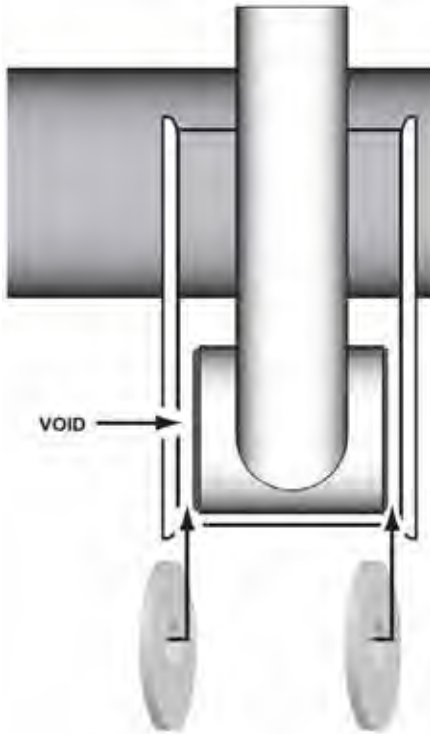

ATTENTION INSTALLER

Install Control Arms ONE AT A TIME for easiest alignment of mounting hardware.

Installation

- ❑ 1. REMOVE ORIGINAL LOWER SUSPENSION ARM
 - Raise and support the vehicle chassis with jack stands.
 - FRONT INSTALLATION – Position behind front lower suspension arm brackets.
 - REAR INSTALLATION – Position in front of rear lower suspension arm brackets.
 - Raise the axle housing back into position and support with a hydraulic jack. HINT: The axle housing should be evenly supported and the suspension at normal ride height. Do not attempt removal or installation with the suspension extended, or the axle drooped, as this will place tension on suspension arm mounting hardware.
 - Remove the lower suspension arm nut and bolt from the axle housing bracket. Retain the original mounting hardware.
 - FRONT INSTALLATION – If front axle is equipped with cam adjusters (see illustration below), scribe or paint alignment marks for re-installation reference.

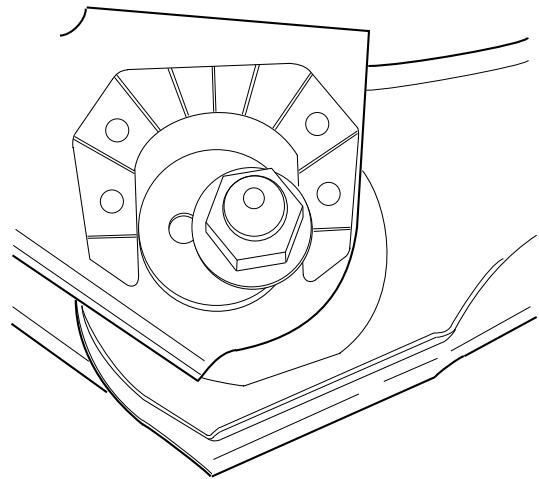

- Remove the nut and bolt from the chassis rail bracket. Retain the original mounting hardware.
- Remove the original lower suspension arm from the vehicle.

-
- ❑ 2. INSTALL CONTROL ARMS
 - Install the arms in the frame and axle mounts so that the bend is down and closer to the front axle.
 - **GRAND CHEROKEE WJ ONLY** - Insert two (2) 1/8" shims (included in JKS6109)– one on each side of bushing – to fill the void between the frame bracket and control arm bushing. Install the original mounting bolt and finger

tighten the nut. **DO NOT torque mounting hardware until instructed.**

- **GRAND CHEROKEE WJ ONLY** - Insert two (2) 1/4" shims (included in JKS6109)– one on each side of the control arm bushing - to fill the void between the axle bracket and control arm bushing.
- Install the original mounting bolt and finger tighten the nut. Remember to realign cam adjuster on front axle if equipped. **DO NOT torque mounting hardware until instructed.**

HINT: If mounting bolt is difficult to install due to misalignment of control arm bushing with mounting bracket, either (1) adjust height of axle housing with hydraulic jack, (2) move axle housing into position with a heavy-duty ratchet strap, or (3) temporarily disconnect track bar until mounting holes align.

SUSPENSION COMPONENTS THAT HAVE RUBBER BUSHINGS must be tightened with vehicle on level ground and at normal ride height. The springs must be supporting the weight of the vehicle when the hardware is torqued; or else ride comfort could be affected and premature bushing wear may occur.

RUBBER BUSHINGS MUST NEVER BE LUBRICATED, as doing so will impair performance and longevity.

©2016 JKS Manufacturing
Revision Date 04/08/2016

❑ 3. TIGHTEN MOUNTING HARDWARE

- Once all control arms have been properly installed, lower the vehicle to the ground until coil springs are supporting the full weight of vehicle.
- Using a torque wrench, tighten the mounting hardware to the factory torque specifications for your vehicle.

Wrangler TJ, 1997-06

- Tighten nut at FRONT axle and chassis brackets to 130 ft-lbs.
- Tighten nut at REAR axle and chassis brackets to 150 ft-lbs.

Grand Cherokee ZJ, 1993-98

- Tighten nut at FRONT axle and chassis brackets to 130 ft-lbs.
- Tighten nut at REAR axle and chassis brackets to 130 ft-lbs.

Grand Cherokee WJ, 1999-04

- Tighten nut at FRONT axle and chassis brackets to 130 ft-lbs.

Cherokee XJ, 1984-01

- Tighten nut at FRONT axle and chassis brackets to 130 ft-lbs.

❑ 4. POST-INSTALLATION INSTRUCTIONS

- If track bar was disconnected during the install, torque axle to track bar bolt to 50 ft-lbs.
- Double check all hardware has been torqued.