



# INSTALLATION INSTRUCTIONS

**Product: Quicker Disconnects™**  
**Part Number: JKS3100 - JKS3104**

**Applications: Grand Cherokee WJ, 1999-2004**

517-278-1226 • jks@sporttruckusainc.com • www.jksmfg.com  
491 W. Garfield Avenue, Coldwater, MI 49036

## Welcome

CONGRATULATIONS on purchasing a set of new Quicker Disconnects™ from JKS Manufacturing. We are committed to providing you with the best products available and your satisfaction is our first priority.

PLEASE READ these Installation Instructions carefully, and save them for future reference, as they contain important installation and maintenance information.

## Tools Required

- Metric/Standard Socket Wrench Set
- Torque Wrench
- Medium Strength Threadlocker
- #1 Philips Screwdriver or Small Punch
- Angle Measuring Tool
- 15/16" Open-End Wrench
- Grease Gun with Zerk Fitting Coupler
- Wheel Bearing Grease
- 7/32 Drill Bit
- Drill
- Factory Service Manual (recommended)

*\* Asterisk denotes tools that are not required for some applications. Thoroughly read instructions first to determine which tools will be required for your application.*

## Parts

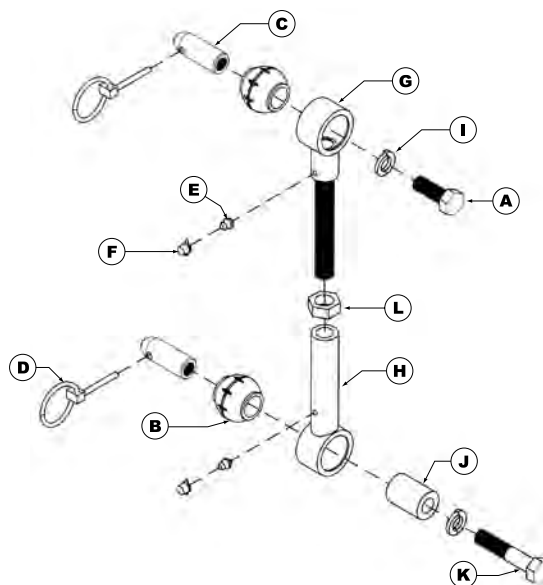

	Description
A	1/2" x 1-1/4" NF GR5 Bolt
B	Spherical Bushing
C	Stainless Steel Post
D	Click Pin
E	Press-In Grease Zerk
F	Grease Zerk Cap
G	Upper Male Threaded End
H	Lower Female Threaded End
I	1/2" Lock Washer
J	OE Bracket Spacer
K	1/2" x 2-1/2" NF GR5 Bolt
L	5/8" Jam Nut

## Important Product Safety Information

For your safety and the safety of others, please read all instructions and warnings in this pamphlet and your Jeep® owner's manual and off road driving supplement before attempting installation. Within these instructions the following signal words refer to important product safety information:

### WARNING

Indicates hazards or unsafe situations which could result in **severe personal injury or death**.

### CAUTION

Indicates hazards or unsafe situations which could result in property damage or minor to moderate personal injury.

### NOTICE

Careful attention is required to this operation that generally does not relate to personal injury, although damage to your JKS product or other property may result if you fail to follow instructions.

### WARNING

Higher Rollover Risk



Modifying your Jeep® to improve off-road performance may result in vehicle handling different than as factory equipped, including increased ride-height and/or chassis articulation; reduced lateral stability and higher risk of roll-over or other accident. Also, owner's choice of larger tire and wheel combinations may require additional braking force or increased stopping distances.

### To reduce risk of serious injury and accident:

- Choose modifications that balance your actual highway & off-road use.
- Avoid sharp turns, abrupt maneuvers or steep side-cambers.
- Avoid other maneuvering conditions which may cause the vehicle to trip, roll, lose traction or compromise your ability to safely brake in an emergency.
- Routinely inspect your vehicle components for unusual wear or off-road damage. Repair or Replace any unserviceable components before use.
- Do not modify or combine body lifts with other mechanical lifts contrary to manufacturers' or Jeep® recommendations & warnings.
- Acquaint any other drivers with your vehicle modifications and handling.
- Always wear seat belts and/or appropriate off-road restraints, reduce your speed, Tread Lightly®.

## Important

**NOT COMPATIBLE WITH** aftermarket swaybars. Install product with Original Equipment swaybar only.

**SOME VEHICLES MAY REQUIRE** extended front brake hoses or other modifications to compensate for additional suspension travel.

**NEVER DISCONNECT** swaybar when operating vehicle on public roads.

**WHEN DISCONNECTED**, the Quicker Disconnects must be completely removed from vehicle, and the swaybar must be secured to the chassis in the horizontal position to prevent interference with tires.

### WARNING

#### Stay Connected On-Road

On-highway safety is enhanced by controlling body roll. Never disconnect swaybar when operating on public roads.

### WARNING

To assure intended performance JKS® Quicker Disconnects™ are **NOT COMPATIBLE** with aftermarket Swaybars. Install **ONLY** with Jeep® factory sway bar.

On-highway safety is enhanced by controlling body roll. Never disconnect swaybar when operating on public roads. When disconnected off-road, swaybar

must be secured to prevent interference with other suspension components.

Brakelines must be secured and retain some slack throughout range of suspension travel. Check after installation of Quicker Disconnects™ & use longer DOT approved brakelines if necessary.

## Installation

- ❑ 1. REMOVE ORIGINAL EQUIPMENT (OE) SWAYBAR LINKS
  - Remove front swaybar drop links and mounting hardware per the factory service manual instructions for your vehicle.
- ❑ 2. INSTALL UPPER MOUNTING POSTS
  - Mount the tapered Stainless Steel Post (C) on the outboard side of the swaybar, ensuring small Click Pin holes are horizontal or parallel with the ground



- Apply medium strength threadlocker to the tip of 1/2" x 1-1/4" Bolt (A).



- Secure tapered post to swaybar by inserting the 1/2" x 1-1/4" Bolt (A) and 1/2" Lock Washer (I) from

the inboard side and tighten to 65 ft-lb. using a torque wrench.

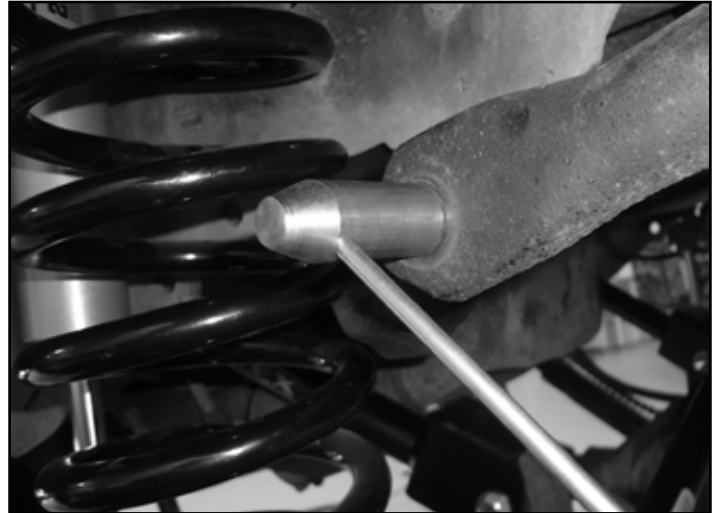

**HINT:** A small Philips head screwdriver or punch inserted into the Click Pin hole will enable you to prevent the mounting post from rotating when tightening the nut.

- ❑ 3. INSTALL LOWER MOUNTING POSTS

- Locate the original lower drop link U-bracket on the axle housing. Insert the steel OE Bracket Spacer (J) into the U-bracket.

**IMPORTANT:** The supplied OE Bracket Spacers must be installed to prevent the U-bracket from collapsing when the mounting bolt is tightened.

- Apply medium strength threadlocker to the tip of 1/2" x 2-1/2" Bolt (K).
- Insert the 1/2" x 2-1/2" Bolt (K) with 1/2" Lock Washer (I) completely through the holes in U-bracket and OE Bracket Spacers (J) from the inboard side of bracket.



- Thread the tapered Stainless Steel Post (C) on to the 1/2" x 2-1/2" Bolt (K) from the outboard side of U-bracket and and tighten to 65 ft-lb. using a

torque wrench. Ensure the small Click Pin holes are horizontal or parallel with the ground.

❑ 4. SET QUICKER DISCONNECT LENGTHS

- Determine the ideal Swaybar Angle for your vehicle according to the following chart.

Vehicle	Part Number	Maximum Length *	Ideal Swaybar Angle (Acceptable Range)
WJ Grand Cherokee	PN 3100	9-3/8"	30°
	PN 3104	11-5/8"	(25°-35°)

**IMPORTANT: DO NOT exceed Maximum Length (measured from center-to-center of bushings) indicated for your part number.**

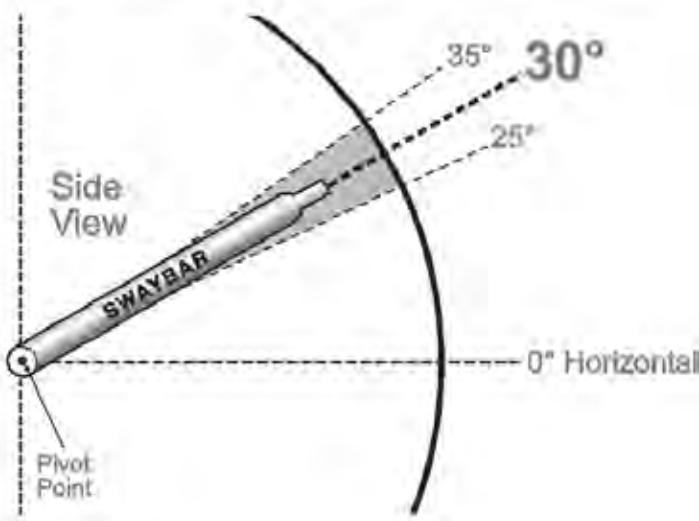

- Adjust the length of your Quicker Disconnects until swaybar is at the Ideal Angle or within Acceptable Range. Vehicle must be at normal ride height and located on level ground.
- Once adjusted, lay Quicker Disconnects on a flat surface and tighten 5/8" Jam Nuts (L) firmly against the Lower Ends (H).

**IMPORTANT: Bushing cradles at both ends of Quicker Disconnect must remain parallel with each other when Jam Nut is tightened.**

❑ 5. INSTALL QUICKER DISCONNECTS

- Slide Upper Ends (G) and Lower Ends (H) of Quicker Disconnects onto the Tapered Mounting Posts (C).
- Insert Click Pins (D) as illustrated to secure.

**CORRECT**

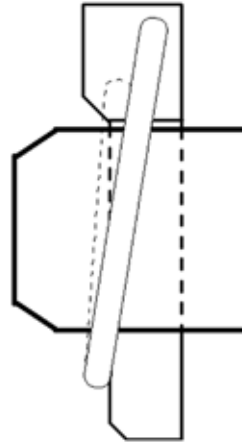

**WRONG**

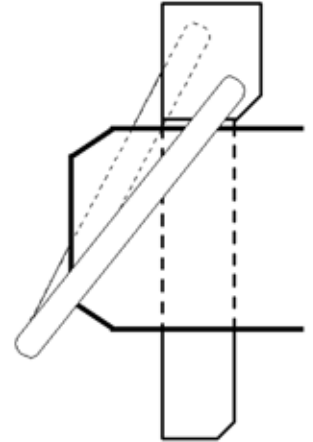

**Important: When properly installed, the ring on the Click Pin will "snap" against the shaft of pin. When installed backwards, the ring does not fit snugly against shaft.**



❑ 6. LUBRICATE QUICKER DISCONNECTS

- Lubricate all Grease Zerk fittings on the Quicker Disconnects immediately after installation using common wheel bearing grease or equivalent.

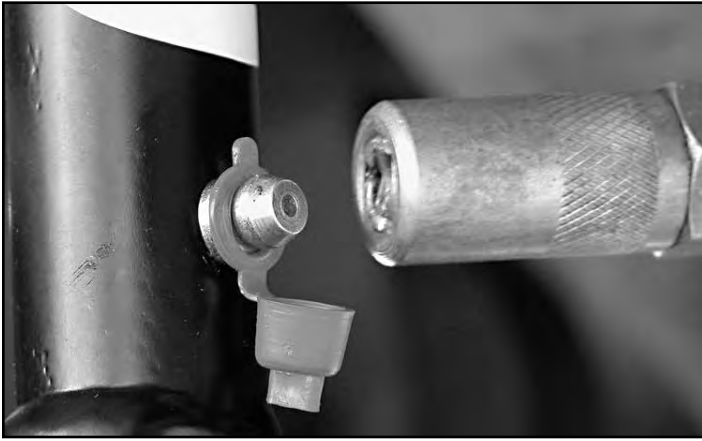

It is important to lubricate Quicker Disconnects frequently for the first three (3) months after installation to evacuate contaminants that may build up during break-in period.

After break-in period, Quicker Disconnects should be lubricated regularly as part of vehicle maintenance schedule.

Regular cleaning with pressurized water is recommended to maximize ease of operation and reliability. Always lubricate afterwards to evacuate any moisture.

---

©2018 JKS Manufacturing, Inc & Aftermarketing, LLC  
Revision Date 04/13/18

---

## ❑ 7. CORRECT OPERATION OF QUICKER DISCONNECTS

- Remove the Click Pins (D) from the Upper and Lower Tapered Mounting Posts (C).
- Completely remove Quicker Disconnects from vehicle and store safely inside vehicle.

**HINT:** To avoid losing Click Pins, reinstall them on mounting posts while Quicker Disconnects are removed.

**IMPORTANT:** When disconnected, the swaybar must be secured in the horizontal position to prevent interference with the tires. Failure to secure the swaybar correctly can lead to severe tire damage.

- To reconnect, remove Click Pins (D) from mounting posts and rotate swaybar down.
- Slide Quicker Disconnects back onto mounting posts and reinstall Click Pins.

---

If you encounter any problems with your installation and setup, please contact JKS Manufacturing for technical assistance.

### JKS Technical Support

Phone	517-278-1226
E-Mail	jks@sporttruckusainc.com

## Troubleshooting

If swaybar does not rotate freely, remove from vehicle, clean and apply rubber lubricant to chassis-mounted bushings, and reinstall.

## Maintenance