



INSTALLATION INSTRUCTIONS

Product: Hydraulic Bump Shocks

Part Number: JKSBSE251

Applications: Wrangler JK, 2007+ (rear only)

517-278-1226 • tech@jksmfg.com • www.jksmfg.com
491 W. Garfield Avenue, Coldwater, MI 49036

Welcome

CONGRATULATIONS on purchasing a set of new Hydraulic BumpShocks from JKS Manufacturing! We are committed to providing you with the best products available and your satisfaction is our first priority.

PLEASE READ these Installation Instructions carefully, and save them for future reference, as they contain important installation and maintenance information.

Important

INSTALLATION of this product is not reversible and should only be performed by an experienced mechanic or fabricator.

CHASSIS MODIFICATIONS are required to install this product. Do not attempt installation if you are inexperienced or uncomfortable with cutting and welding on your vehicle's frame.

THESE INSTRUCTIONS provide an overview of the installation process only, and are in no way a substitute for the experience one needs to do the job properly.

DO NOT EXCEED maximum range of bump shock adjustment – see illustration on page 4.

Tools Required

- Hydraulic Floor Jack and Jack Stands
- Metric/Standard Socket Wrench Set
- Spanner or Strap Wrench *
(or similar tool for tightening Bump Shock Nut)
- Metal Cutting Tool (for cutting through frame)
- Grinding/Sanding Tool
(for light material removal and smoothing)
- Emory Cloth
(or similar abrasive for paint/plating removal)
- Tape Measure
- Felt Tip Marker (or similar marking tool)
- Clamping Tool *
(for holding product in place during welding)
- Welding Equipment
- Drill with 1/8" and 3/8" Bits
- Coil Spring Compressor *
- Spray Lubricant (WD-40 or equivalent)
- Anti-Seize Lubricant
- Satin Black Spray Paint
- Factory Service Manual (recommended)

* Asterisk denotes tools that are not required for some applications. Thoroughly read instructions first to determine which tools will be required for your application.

Parts

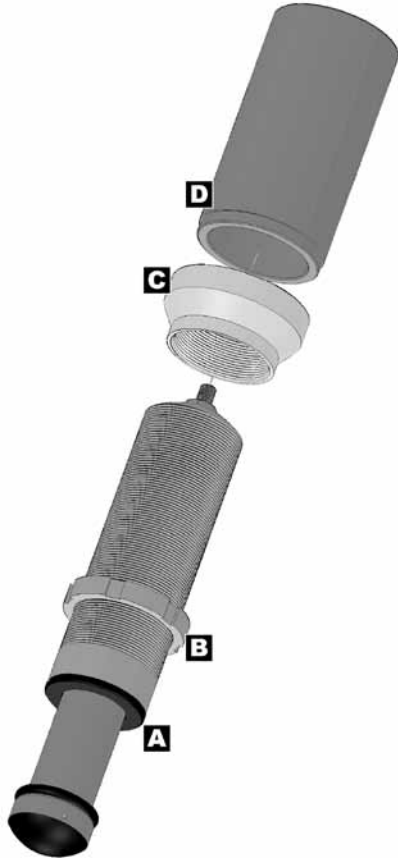

| | Description | Part # | QTY |
|----------|-------------------------|----------|-----|
| A | Bump Shock Assembly | RFC/BS02 | 2 |
| B | Bump Shock Nut | RFC/SN50 | 2 |
| C | Jounce Adapter | 03154 | 2 |
| D | Bump Shock Chassis Tube | 03155 | 2 |

Installation

1. PREPARE VEHICLE FOR CHASSIS MODIFICATIONS

- Remove rear track bar, shocks, coil springs, and any other components that prevent you from accessing the factory rear bump stop holders. **HINT:** You will need to access this part of the chassis from multiple directions so make sure you have plenty of freedom to work.
- Drill a small hole exactly through the center of the factory upper bump stop holders and into the chassis. Make sure drill is square with chassis. **HINT:** This provides a reference point to work from during installation, as center of BumpShock must remain at the same centerline as the factory bump stop.

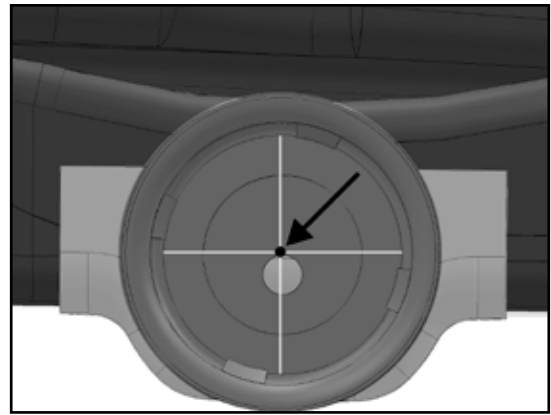

- Remove the factory upper bump stop holders from the chassis brackets. **HINT:** The bump stop holder is welded to the chassis bracket and must be cut free.



- Next remove the factory bump stop brackets from the chassis. **HINT:** The bracket is welded to the chassis along its perimeter. It must be carefully removed without gouging or otherwise damaging the chassis.
- With the bump stop holders and brackets removed, clean the chassis of any remaining weld material until smooth.

2. FRENCH CUT CHASSIS

The chassis rails must be frenched to accept the supplied Chassis Tubes (D). When executed correctly, the Hydraulic BumpShock will be positioned on the same centerline as the OE bump stop holder (identified by the previously drilled reference hole). Also, the BumpShock must contact the center of the landing pad on the axle when the suspension is compressed.

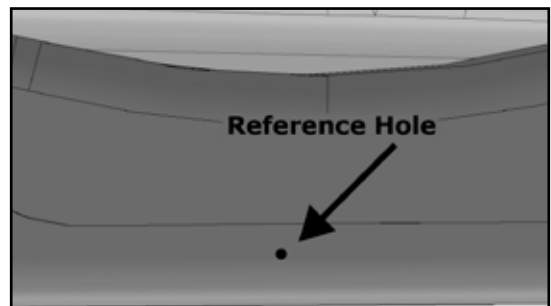

- Using the reference hole illustrated above as the center point, mark a 2.5" diameter circle on the bottom of the chassis rail. This indicates the material to remove in order to accommodate the supplied Chassis Tubes (D).

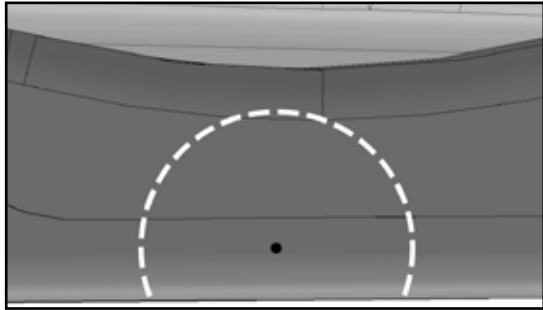

- Transfer the markings from the bottom of the chassis onto the outer side of the frame rail.

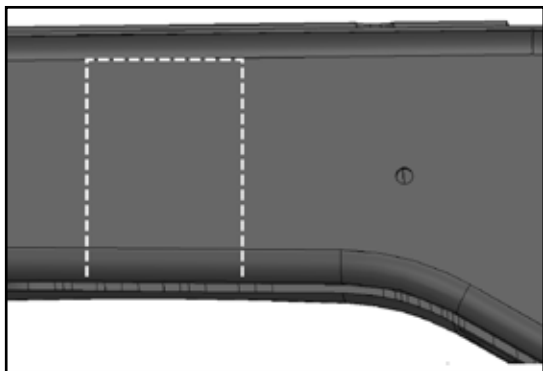

- If necessary, adjust the markings on the chassis to ensure they are in alignment with the landing pad on the axle at full suspension compression.
- Carefully cut along the marked lines using an appropriate cutting tool. Only remove as much material from the chassis as necessary to accommodate the Chassis Tube (D). Always err on the conservative side when removing material from the chassis rail. Welding the Chassis Tube in place will be easiest with a tight fit-up and minimal gaps.



3. INSTALL JOUNCE ADAPTER ON CHASSIS TUBE

- Locate the supplied Jounce Adapters (C). The adapters are zinc plated from the factory to prevent corrosion. In preparation for welding, a small amount of plating must be removed to ensure the areas to be welded are clean.
- Slide the enlarged (non-threaded) end of the Jounce Adapter (C) onto the Chassis Tube (D) until fully seated. Hold in position while completing the next step.
- Mark the perimeters of the Chassis Tube (D) AND the Jounce Adapter (C) where they meet at three (3) locations that are accessible for welding. Each weld location should be at least 1/2" in length and spaced evenly apart. **HINT:** A felt tip marker or similar marking tool is useful for marking weld locations.

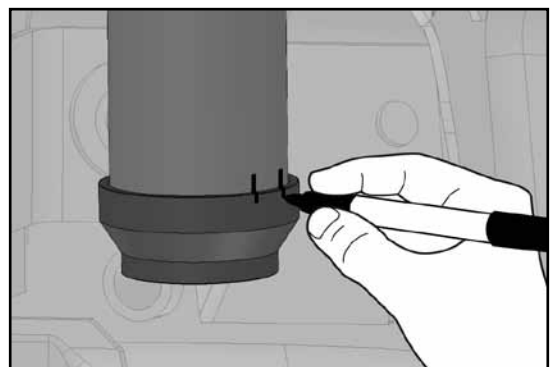

HINT: A pair of vertical lines spaced 0.5" apart is used to mark each weld location.

3. WELD CHASSIS TUBE IN PLACE

- Position the Chassis Tube (D) in the notched frame rail and make sure it is properly aligned.
- Securely clamp the Chassis Tube (D) in place to prepare for welding.
- Tack weld the Chassis Tube (D) to the frame rail in several locations to prevent it from shifting during final welding.
- Check the position and alignment of the Chassis Tube (D) one last time to make sure the Hydraulic BumpShock will contact the landing pad as intended.
- Weld the Chassis Tube (D) to the frame rail until the gap between them is completely filled. Avoid overheating frame rail by stopping to allow the surface to cool off regularly.

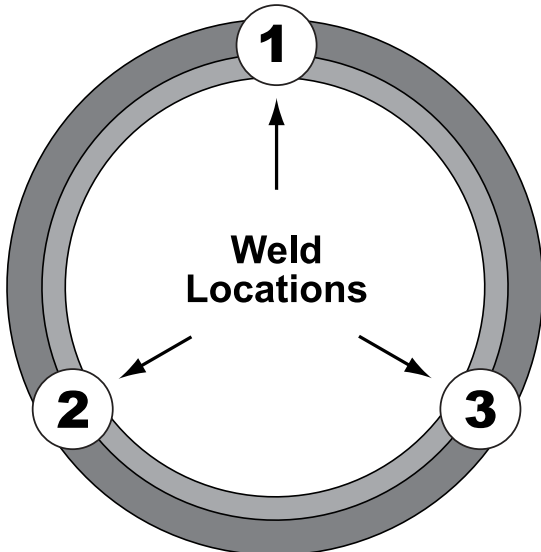
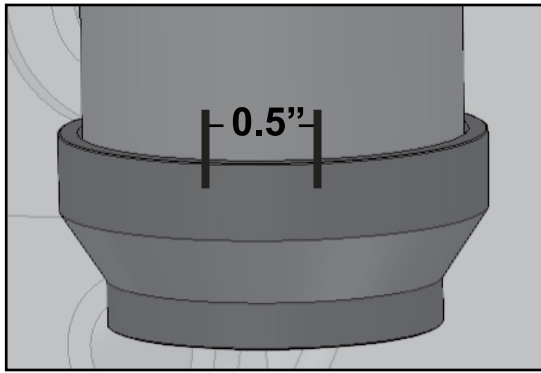

- Remove Jounce Adapter (C) from Chassis Tube (D) and locate the weld location markings on both components.
- Remove the zinc plating from the marked locations on the Jounce Adapter (C). **HINT:** Emory cloth or a suitable stripping tool is useful for removal of coatings. Make sure bare metal is completely exposed and free of contaminants to ensure proper weld penetration.
- Reposition the Jounce Adapter (C) on the Chassis Tube (D), making sure the locations prepped for welding are in alignment.

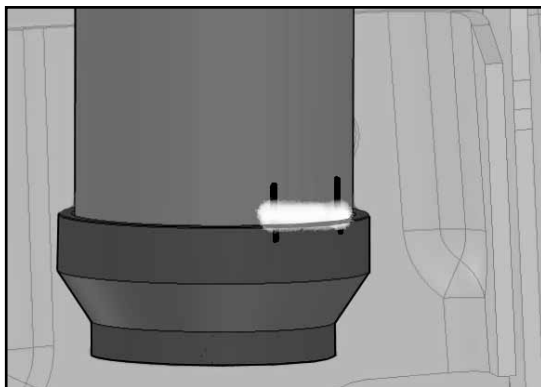

- Tack weld the Jounce Adapter (C) to the Chassis Tube (D) at each location. Make sure the adapter has remained fully seated against the tube before proceeding.

- Next, weld a 1/2" long bead over each tack weld to ensure the Jounce Adapter (C) remains secured to the Chassis Tube (D). **HINT:** As long as you achieve proper weld penetration on the adapter and spring retainer, it is not necessary to weld around the entire perimeter.

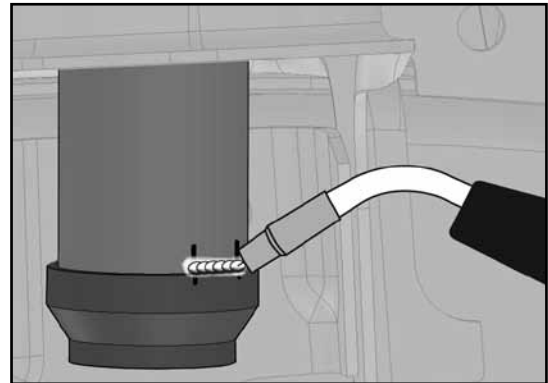

- Allow the welded sections to cool and then drill a 3/8" hole through the Chassis Tube (D) immediately above one of the welds. **HINT:** The purpose of the hole is to facilitate the evacuation of any moisture that may collect inside the tube.

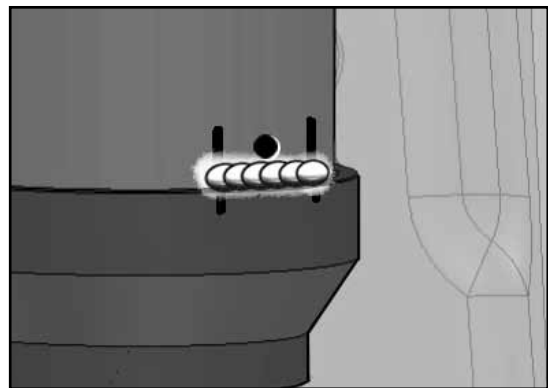

- To prevent corrosion, it will be necessary to paint all exposed surfaces on the Jounce Adapter (C) and Chassis Tube (D). Prepare for painting by thoroughly cleaning any dirt, debris or deposits from the area. **HINT:** A clean piece of emory cloth or equivalent is useful for preparing the area to be painted.
- Completely cover the exterior of the Jounce Adapter (C) and all exposed metal on the Chassis Tube (D) with satin black spray paint. Protect inner threads of adapter from overspray.

5. INSTALL BUMP SHOCK ASSEMBLY

- Apply anti-seize lubricant to internal threads of Jounce Adapter (C) and Bump Shock Nut (B).
- Completely thread the Bump Shock Nut (B) onto Bump Shock Assembly (A).
- Thread Bump Shock Assembly (A) into Jounce Adapter (C) as far as possible.

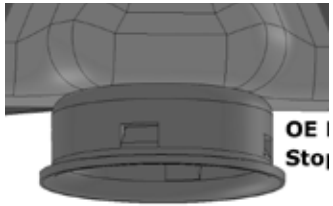

IMPORTANT: Internal threads of Jounce Adapter must remain fully engaged with Bump Shock Assembly at all times. Never operate vehicle when more than 3.25" of bump shock threads are exposed as illustrated above.

- Once the Bump Shock Assembly (A) is properly adjusted for your application, lock in place by turning the Bump Shock Nut (B) clockwise until it contacts the Jounce Adapter (C) and tighten. **HINT:** A spanner or strap wrench is useful for tightening Jounce Adapter Nut.

- Re-install the rear coil springs and any of the components that were removed during the PRE-PARE VEHICLE FOR CHASSIS MODIFICATIONS section of this installation.

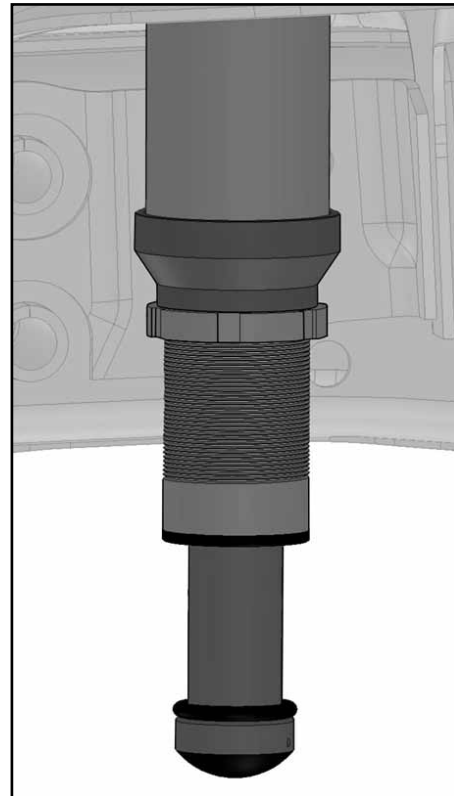

IMPORTANT: The suspension must be fully cycled to test for bump shock alignment and interference issues before the vehicle can be safely operated. The bump shock must contact the center portion of the lower spring pad at full compression, and there should be no interference between the bump shock and coil spring at full extension.

6. ADJUST BUMP SHOCK POSITION

The ideal bump shock position is determined by the vehicle suspension and varies for each application.

- To properly set the bump shock position for your vehicle, you must first decide the point at which suspension compression should be limited. Take into consideration coil springs, shock absorbers, tire clearance, or any other factors that cause the vehicle to bottom out.

IMPORTANT: Because it replaces the original rubber bump stop, the bump shock should determine the limit of compression travel. The bump shock should be fully compressed when the suspension reaches maximum desired compression.

- With the vehicle on level ground and the suspension at full droop, extend the Bump Shock Assembly (A) to the desired position.

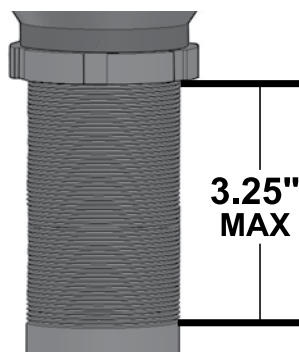

Operation

Bump Shock Adjustments

Never attempt to adjust the Bump Shock Assembly (A) while under tension and always apply spray lubricant to threads before adjusting for ease of operation.

Bump Shock Pressure

The Bump Shock Assembly (A) is pre-charged with the proper amount of Nitrogen gas to suit most applications. Therefore it should not be necessary to adjust bump shock pressure prior to installation.

The Nitrogen charge is factory preset at 150 psi. For applications that require a higher or lower compression rate, the gas pressure can be manually adjusted to a minimum of 100 psi and a maximum of 200 psi.

To adjust pressure, the Bump Shock Assembly (A) must be removed from the vehicle. Nitrogen pressure is adjusted through the Schrader valve on top of the bump shock. Care should be taken when discharging the bump shock to ensure that no oil is lost. Most shops that service off-road racing or motorcycle shock absorbers can adjust bump shock pressure.

Maintenance

Regular cleaning with pressurized water is recommended to maximize ease of operation and reliability.

In addition, the 3/8" drainage holes that you drilled immediately above the Jounce Adapters (C) must be checked periodically for blockages. If necessary, clear debris from the holes to ensure any moisture trapped inside spring retainer is able to self-evacuate.

©2013 JKS Manufacturing, Inc & Aftermarketing, LLC
Revision Date 10/31/2013