



INSTALLATION INSTRUCTIONS

Product: Steering Stabilizer Tie Rod Mount

Part Number: JKSOGS924

Applications: Wrangler JK, 2007+

517-278-1226 • tech@jksmfg.com • www.jksmfg.com
491 W. Garfield Avenue, Coldwater, MI 49036

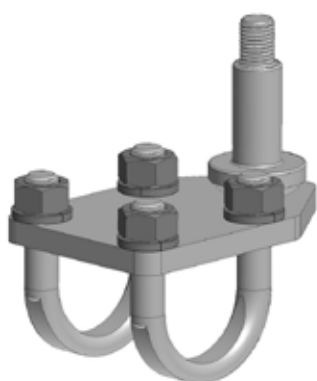

Welcome

CONGRATULATIONS on purchasing a new Steering Stabilizer Tie Rod Mount from JKS Manufacturing. We are committed to providing you with the best products available and your satisfaction is our first priority.

PLEASE READ these Installation Instructions carefully, and save them for future reference, as they contain important installation and maintenance information.

Important

NOT COMPATIBLE WITH the OE steering stabilizer. Make sure you have an aftermarket steering stabilizer with 5/8" ID bushing before attempting installation.

Tools Required

- Metric/Standard Socket Wrench Set
- Torque Wrench
- Tape Measure *
- Factory Service Manual (recommended)

* Asterisk denotes tools that are not required for some applications. Thoroughly read instructions first to determine which tools will be required for your application.

Parts

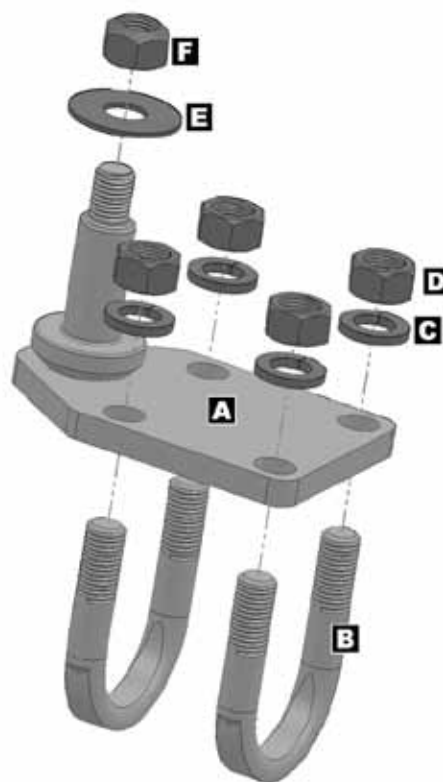

	Description	Part#	QTY
A	Tie Rod Bracket Assembly	030104	1
B	U-Bolt Strap	761120214R	2
C	7/16" Split Lock Washer	33624	4
D	7/16" GR5 Nut	36358	4
E	7/16" Fender Washer	33010	1
F	7/16" Ovalok Nut	37306	1

Installation

❑ 1. REMOVE OE TIE ROD MOUNT

- Remove the steering stabilizer retainer nut from the factory mount on the tie rod.
- Remove end of stabilizer from factory mount.
- Remove the hardware that secures the factory stabilizer mount to the tie rod.
- Remove the factory stabilizer mount from the vehicle and discard along with original hardware.

❑ 2. INSTALL NEW STEERING STABILIZER TIE ROD MOUNT

- To ensure a proper fit, clean any dirt, debris or grease from surface of tie rod where the stabilizer was mounted.
- Determine the ideal configuration and placement of the Steering Stabilizer Tie Rod Mount on the tie rod. Take into consideration the following factors:
 - Stabilizer mount on tie rod should be aligned with stabilizer mount on axle. There should be no binding of the stabilizer or its bushings throughout its entire stroke.
 - Mounting position on tie rod must allow unrestricted steering from lock-to-lock.
 - Tie Rod Mount and steering stabilizer must not interfere with differential cover on axle.
- For maximum versatility, the Steering Stabilizer Tie Rod Mount can be installed in various configurations based on your individual vehicle requirements. The following are just two of the most common configurations:

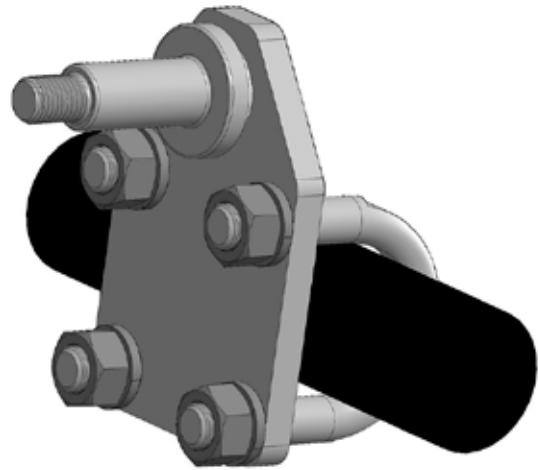
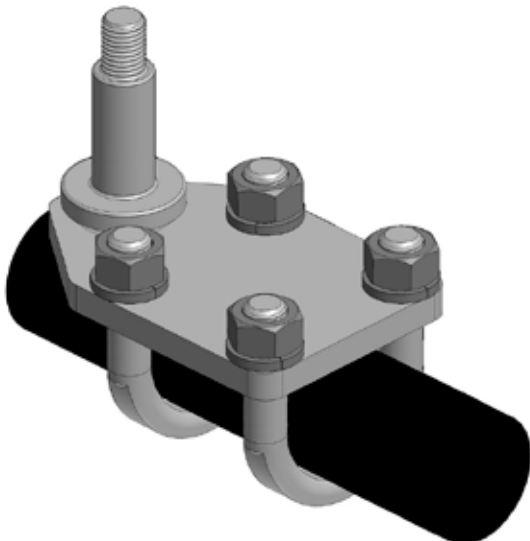

- Place the Tie Rod Bracket Assembly (A) on the tie rod in the desired configuration and loosely install the U-Bolt Straps (B) along with the 7/16" Split Lock Washers (C) and 7/16" GR5 Nuts (D). Do not tighten hardware yet.

IMPORTANT: This product is not compatible with the factory steering stabilizer. An after-market damper with 5/8" ID bushings must be installed.

- Slide end of steering stabilizer onto mounting stud of Tie Rod Bracket Assembly (A) followed by the supplied 7/16" Fender Washer (E) and 7/16" Ovalok Nut (F).

IMPORTANT: If stabilizer bushing contains a metal sleeve, remove it to allow fitment.

- Tighten 7/16" Ovalok Nut (F) until the Fender Washer (E) bottoms on the mounting stud.
- With the Steering Stabilizer Tie Rod Mount loosely installed on tie rod, find a position that allows unrestricted lock-to-lock steering and full steering stabilizer travel.
- Once the final mounting position is established, evenly tighten each of the 7/16" GR5 Nuts (D) to 35 ft-lbs. using a torque wrench.

©2013 JKS Manufacturing, Inc & Aftermarketing, LLC
Revision Date 11/1/2013