

# JKS<sup>®</sup>

## Installation Instructions



Product: **OE Replacement Rear Trackbar Bracket**

Part Number: **PN OGS168**

Application: **Jeep Wrangler JK, 2007+ (rear)**

### Welcome

CONGRATULATIONS on purchasing a new OE Replacement Rear Trackbar Bracket from JKS Manufacturing. We are committed to providing you with the best products available and your satisfaction is our first priority.

PLEASE READ these Installation Instructions carefully, and save them for future reference, as they contain important installation and maintenance information.

### Important

**INSTALLATION REQUIRES WELDING** by a qualified welder or metal fabricator.

### Tools Required

- Metric/Standard Socket Wrench Set
- Torque Wrench
- Tape Measure
- Die Grinder with Cut-Off Wheel (for removing factory brackets)
- Grinding Wheel
- 6" Clamp or larger (or similar tool to hold bracket in place during welding)
- Welding Equipment
- Satin Black Spray Paint
- Angle Measuring Tool
- Anti-Seize Lubricant \*
- Factory Service Manual (recommended)

\* Indicates tool that may not be necessary for every installation. Thoroughly read instructions in advance to determine which tools will be required for your application.

### Recommended Upgrade

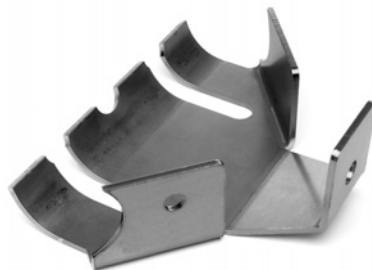

For maximum strength and to prevent future damage from occurring, we strongly recommend the installation of our optional Rear Trackbar Brace PN OGS169.

### Installation

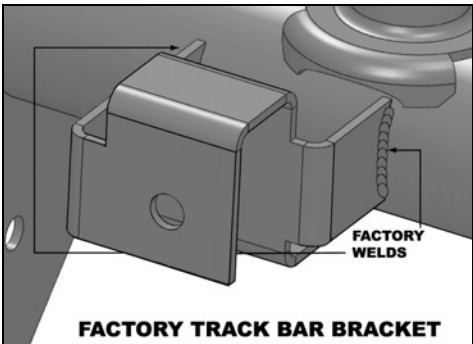
1. **REMOVE REAR TRACK BAR**
  - Remove rear track bar mounting hardware from axle and chassis brackets per the factory service manual instructions for your vehicle. Retain original hardware.
  - Remove rear track bar from vehicle.
2. **REMOVE FACTORY TRACK BAR BRACKET FROM AXLE**
  - Inspect factory track bar bracket on rear axle housing. Locate areas that are welded to the axle tube.

**FACTORY TRACK BAR BRACKET**
  - Cut factory track bar bracket off of axle housing. Use care to avoid cutting into the axle tube. **HINT:** A die grinder with cut-off wheel is useful for cutting off the factory bracket.
  - Remove any remnants of the bracket or factory welds from axle housing until surface of axle tube is smooth. **HINT:** A grinding wheel is useful for removing remaining bracket material.

### ❑ 3. WELD OE REPLACEMENT TRACK BAR BRACKET TO AXLE HOUSING

**IMPORTANT: OE Replacement Bracket must be welded to bare metal. Remove any residual paint, rust or other contaminants before welding.**

- When installed correctly, track bar mounting hole on OE Replacement Bracket will be in exact same position as factory bracket mounting hole. Use the following measurements to ensure your bracket is positioned correctly before welding.

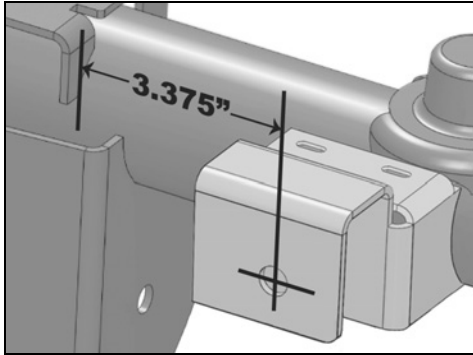

- Distance from center of track bar mounting hole to edge of factory bump stop pad is exactly 3.375".
- Top of OE Replacement Bracket is positioned at same angle as top of factory bump stop pad.
- Position Replacement Bracket on axle housing as instructed and temporarily clamp in the desired mounting location.

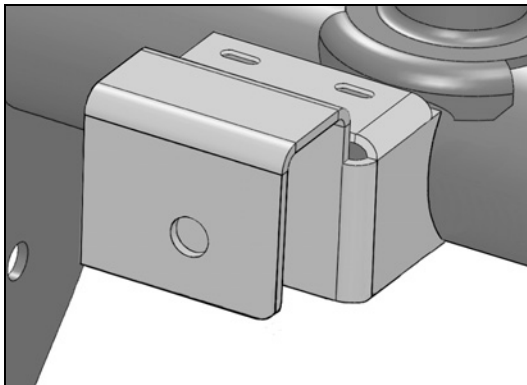

- With Replacement Bracket correctly positioned, tack weld the bracket to axle housing.
- If satisfied, fillet weld Replacement Bracket to axle housing.

**IMPORTANT: Avoid overheating axle tube by allowing surface to cool off regularly.**

- Once all welding is complete, spray paint the entire Replacement Bracket and any bare metal on axle housing to prevent corrosion. All exposed metal must be completely covered.

### ❑ 4. REINSTALL REAR TRACK BAR

- Apply anti-seize lubricant to bolt threads of original track bar mounting hardware.
- Insert axle end of track bar into Replacement Bracket first. Loosely install original mounting hardware.
- Mount chassis end of track bar and loosely install original mounting hardware.

**IMPORTANT: Vehicle must be on level ground with coil springs supporting the full vehicle weight before mounting hardware is tightened.**

- Using a torque wrench, tighten mounting hardware at both ends of track bar to 125 ft-lbs.

## Maintenance

Check torque specifications regularly.

© 2009 JKS Manufacturing, Inc & Aftermarketing, LLC  
Revision Date 8/21/2009