



XP1000 Long Travel Front Control Arms

Polaris XP1000 | 2014-2016

Part #: 5201303

Rev. 092420

491 W. Garfield Ave., Coldwater, MI 49036 · Phone: 517-278-7768

E-mail: sales-rtpro@sporttruckusainc.com

SAFETY WARNING

RT Pro UTV recommends this system be installed by a professional technician. In addition to these instructions, professional knowledge of disassembly/ reassembly procedures and post installation checks must be known.

WHY BUY RT PRO UTV

Great off-road driving and racing comes with having the most rugged and durable machine in the pack.

RT Pro UTV performance enhancing products will make your off-road machine stronger, tougher and safer so you can have more fun and less breakdowns.

For over a decade, RT Pro UTV staff have been taking brand new UTVs and driving them to their breaking point. When they bend, break or falter, we take them back to shop and create a fix that stops the problem from happening again.

There is no other company in the industry that puts more thought, engineering and design innovation into their products than we do. Our team is made up of off-road racers, mechanical engineers and talented fabricators who live and breathe all things motorsport. Above all, we share a passion for innovation, quality construction and getting things right.

All of our products are designed for assembly by weekend warriors with normal garage tools and the occasional spot-weld. Assembly directions are complete and thorough.

Remember, when you buy a RT Pro UTV product for your UTV, all of the parts have been designed and manufactured in the United States with U.S. steel and other high quality American components.



RTP5201303		
Part #	Description	QTY
A2016	XP1000 Front UCA Assembly-DRV	1
A2017	XP1000 Front UCA Assembly-PASS	1
A2018	XP1000 Front LCA Assembly-DRV	1
A2019	XP1000 Front LCA Assembly-PASS	1
04206	UCA Spindle Adapter	2
04207	UCA Spindle Adapter Cap	2
04204	LCA Spindle Adapter	2
04205	LCA Spindle Adapter Cap	2
23351	Spindle Adapter Bolt (3/8-24 x 3/4 SHCS)	4
XP1K-F-6	Front Brake Line Kit	1
04277	Pivot Sleeve	6
04278	Replacement Bushings	12
04280	UCA Rear Bushing	4
04293	UCA Rear Pivot Bushing	2
	M10 x 1.5mm x 55mm SHCS	2
	M10 x 1.5mm Nylock	2

FITMENT NOTES

Long travel kit comes with front sway bar mount standard
 Will not work with Polaris Front Winch
 Wheel offset: Must use 4 inch backspacing or less

SPECIAL TOOLS

None

INSTALLATION TIME

Approximately 6-8 hours
 Hard Difficulty

INSTALLATION INSTRUCTIONS

1. A complete disassembly of all suspension components is required. To do this, lift the vehicle and secure with jack stands. Remove tires, spindle assemblies, control arms, tie rods, radius rods, shocks and axles. Leave sway bar links attached to the sway bar.
2. Refer to the Axle rebuild instructions to swap stock axles with long travel axles
3. Once your RZR is torn down, screw in tie rod into rack, be sure to use red lock tite on threads. re-use the factory tie rod boot on assembly.
4. Assemble lower control arm as shown in Figure 1, Replacement bushings and pivot sleeves are included in this kit. Also install spindle adapter into the outer heim. Use red lock tight on spindle adapter hardware (3/8-24 x 3/4 SHCS)

Figure 1

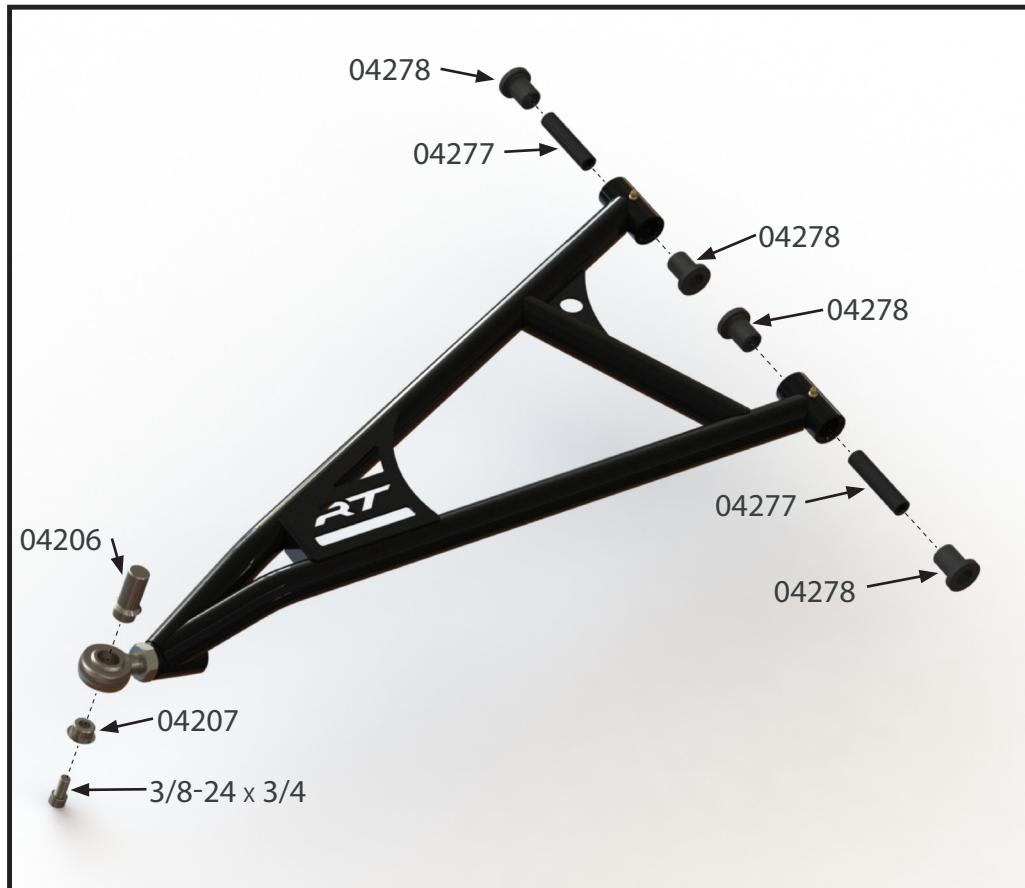

5. Install Lower control arm as shown in Figure 2.

Figure 2



6. Install front axle. Using a dead blow hammer makes this task a bit easier, thread the spindle nut onto the end of the axle and hit from outside inward. while doing so keeping outer joint, inner joint and axle as close to concentric as possible (hit straight in) (Do not hit the inside joint as you will risk tearing the rubber CV boot) See Figure 3.

Figure 3



7. Install spindle onto lower arm spindle adapter as shown in Figure 4. Align the lower control arm spindle adapter to the lower hole in the spindle and insert stock hardware. Hardware should not be forced in, if it is difficult for the hardware to go in ensure holes are concentric and try again.

Figure 4

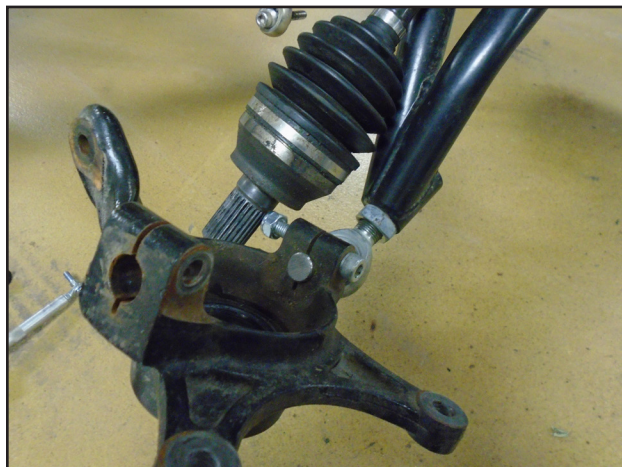

8. Insert end of axle through spindle as shown in Figure 5

Figure 5

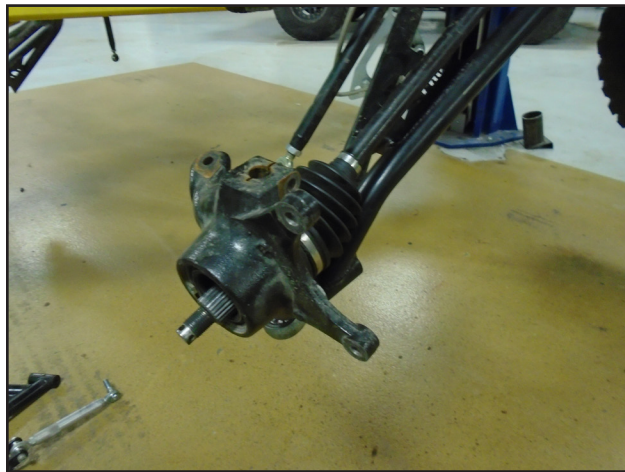

9. Assemble bushings, pivot sleeves and spindle adapter into upper control arm as shown in Figure 6. Use red lock tight on spindle adapter hardware (3/8-24 x 3/4 SHCS).

Figure 6

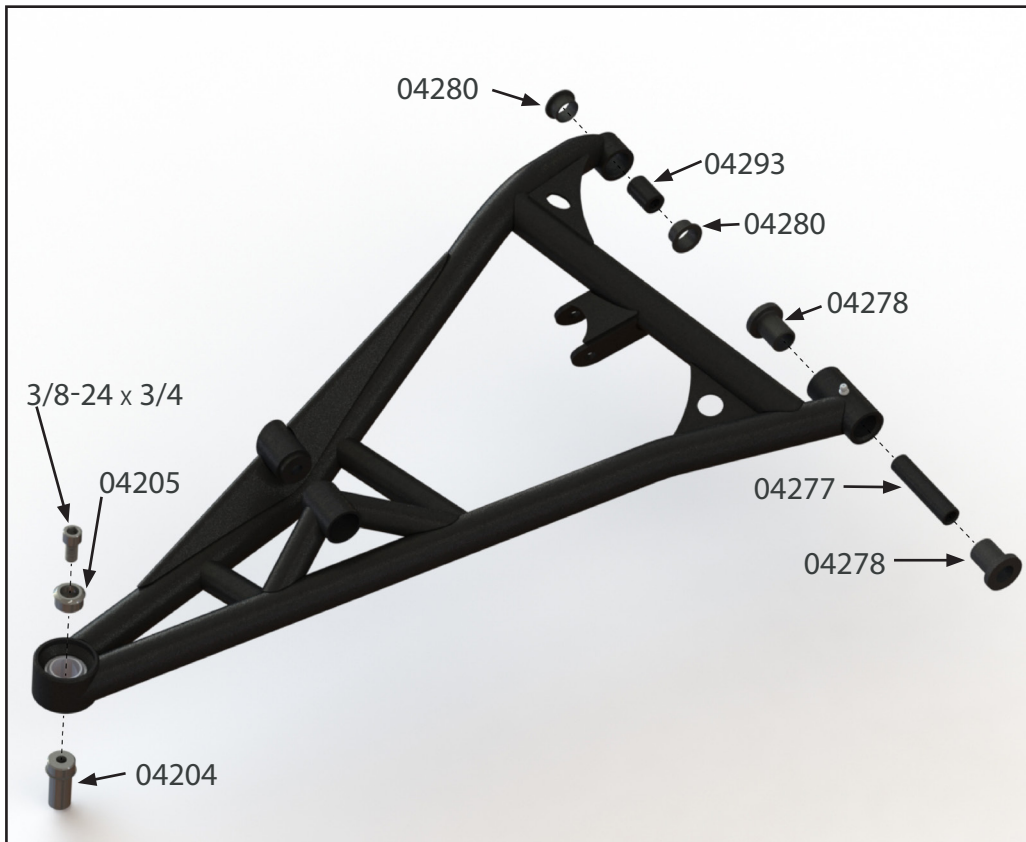

10. Install upper control arm to frame as shown in Figure 7

Figure 7

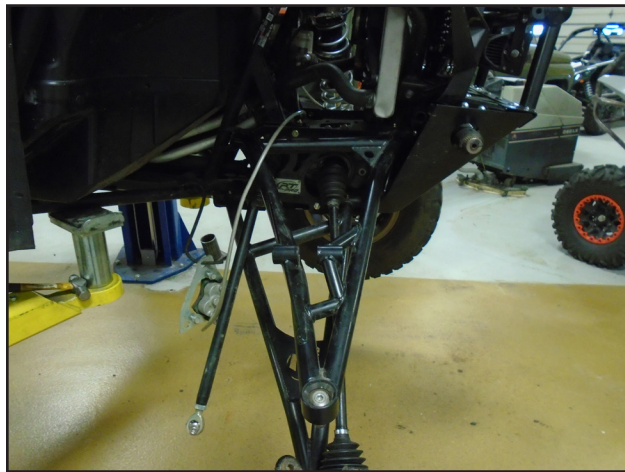

11. Insert upper control arm spindle adapter into the top of the spindle, align the holes and insert hardware. See Figure 8

Figure 8



12. Replace stock brake lines with included brake line kit. Install hub assembly, and caliper to outer spindle as shown in Figure 9. Be sure to route brake lines as shown in Figure 10. Use red loctite on brake caliper bolts.

Figure 9

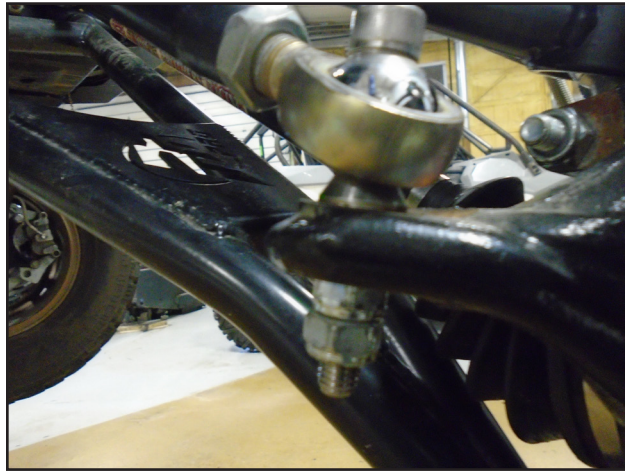

Figure 10



13. Install factory washers and spindle nut on axle. Spindle nut will be torqued to spec at the end of install.
14. Install tie rod to spindle, double nut tie rod hardware. See Figure 11

Figure 11



15. If your machine is equipped with a front sway bar, mount sway bar link to upper control arm mount.
16. Install shock and attach brake lines to upper control arm as shown in Figure 12. Use supplied M10 x 1.5 x 55mm SHCS for lower shock mount.

Figure 12

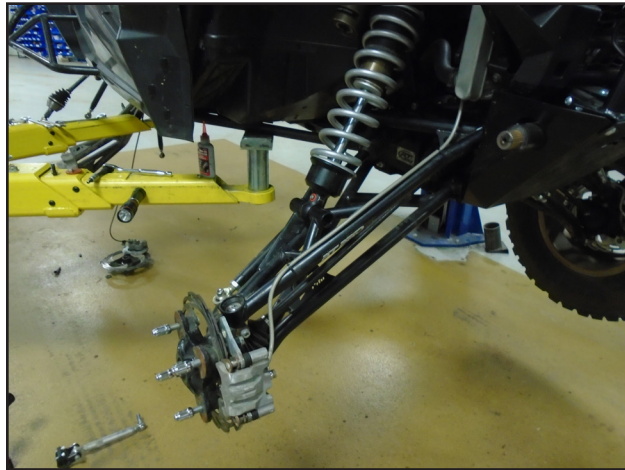

17. Install tires, lower the RZR, and torque spindle nuts to factory specification. once spindle nut is torqued, install cotter pin through the factory castle nut/axle.

ALIGNMENT

18. Before driving, the alignment of the steering **MUST** be centered and we recommend the toe-in should be set at 1/8" inwards overall. You may also set it at 1/8" toe out but we've found toe-in to be the most effective for steering and handling. Once alignment is complete, be sure to tighten tie rod jam nuts.
19. Before setting the camber, settle the vehicle by driving back and forth a few times, just putting weight on a RZR will not get it to the correct ride height. Set camber to 90 degrees or as otherwise desired by threading the lower control arm heim in or out. Once camber is set, tighten jam nut on lower control arm heim.

Figure 14



THANK YOU FOR YOUR BUSINESS!

For questions or additional information, feel free to call and ask for tech support or email us through our website at: rtproutv.com/contact



Show Us Your Ride!

Get a photo of your RT Pro UTV equipped vehicle and send them in for a chance to be featured in our customer gallery!