



J1403 Installation Instructions 1999-2004 Jeep Grand Cherokee WJ 4wd 4" Suspension Lift

Read and understand all instructions and warnings prior to installation of product and operation of vehicle.

Zone Offroad Products recommends this system be installed by a professional technician. In addition to these instructions, professional knowledge of disassembly/ reassembly procedures and post installation checks must be known. Minimum tool requirements include the following: Assorted metric and standard wrenches, hammer, hydraulic floor jack and a set of jack stands. See the "Special Tools Required" section for additional tools needed to complete this installation properly and safely.

» PRODUCT SAFETY WARNING

Certain Zone Suspension Products are intended to improve off-road performance. Modifying your vehicle for off-road use may result in the vehicle handling differently than a factory equipped vehicle. Extreme care must be used to prevent loss of control or vehicle rollover. Failure to drive your modified vehicle safely may result in serious injury or death. Zone Offroad Products does not recommend the combined use of suspension lifts, body lifts, or other lifting devices.

You should never operate your modified vehicle under the influence of alcohol or drugs. Always drive your modified vehicle at reduced speeds to ensure your ability to control your vehicle under all driving conditions. Always wear your seat belt.

» TECHNICAL SUPPORT

Live Chat provides instant communication with Zone tech support. Anyone can access live chat through a link on www.zoneoffroad.com.

www.zoneoffroad.com may have additional information about this product including the latest instructions, videos, photos, etc.

Send an e-mail to tech@zoneoffroad.com detailing your issue for a quick response.

888.998.ZONE Call to speak directly with Zone tech support.

» PRE-INSTALLATION NOTES

1. Special literature required: OE Service Manual for model/year of vehicle. Refer to manual for proper disassembly/reassembly procedures of OE and related components.
2. Adhere to recommendations when replacement fasteners, retainers and keepers are called out in the OE manual.
3. Larger rim and tire combinations may increase leverage on suspension, steering, and related components. When selecting combinations larger than OE, consider the additional stress you could be inducing on the OE and related components.
4. Post suspension system vehicles may experience drive line vibrations. Angles may require tuning, slider on shaft may require replacement, shafts may need to be lengthened or trued, and U-joints may need to be replaced.
5. Secure and properly block vehicle prior to installation of Zone Offroad Products. Always wear safety glasses when using power tools.
6. If installation is to be performed without a hoist, Zone Offroad Products recommends rear alterations first.
7. Due to payload options and initial ride height variances, the amount of lift is a base figure. Final ride height dimensions may vary in accordance to original vehicle attitude. Always measure the attitude prior to beginning installation.

Difficulty Level

easy 1 2 **3** 4 5 difficult

Estimated installation: 4 hours

Special Tools Required

None

Tire/Wheel Fitment

Wheel:

16 x 8, 4.5 - 6" BS

Tire:

31" x 10.5"

Kit Contents

***Important* Verify you have all of the kit components before beginning installation.**

J1403 Box Kit

Qty Part

- 2 Front Coil Spring
- 2 Rear Coil Spring
- 1 A-Arm Spacer
- 1 Loctite - 1ml

Track Bar Parts

- 2 3/4" x 12mm ID x 1.58 sleeve
- 1 Bolt Pack 919
 - 2 12mm x 70mm bolt
 - 3 1/2" SAE washer
 - 1 12mm lock nut

Sway Bar Link Parts

- 2 .625 x .109 x 1.375 Sleeve
- 2 .625 x .075 x 1.375 Sleeve

Transfer Case Drop

- 8 Transfer Case Spacer

Rear Bump Stop Parts

- 1 Bolt Pack 439
- 2 Rear Bump Stop Spacer

J1414 Box Kit

Qty Part

- 2 Fixed LCA w/rubber bushings
- 4 LCA Spacer Washer - 1/4" Thk

- 4 LCA Spacer Washer - 1/8" Thk
- 1 Bolt Pack 725
 - 2 10mm x 65mm bolt
 - 2 10mm lock nut
 - 4 3/8" USS washer
 - 4 8mm x 100mm bolt
 - 4 5/16" USS washer
 - 3 14mm x 80mm bolt
 - 3 9/16" SAE washer
 - 1 1/8" x 1-1/4" cotter pin

Sway Bar Link Parts

- 2 Sway bar link
- 4 5/8 ID hourglass bushing

Front Bump Stops

- 2 3in wide x 2in tall extension

Track Bar Parts

- 1 Front adjustable track bar
- 4 Track bar bushing

Transfer Case Drop

- 1 Bolt Pack 726
 - 4 10mm x 140mm bolt
 - 4 10mm x 100mm bolt
 - 8 3/8" USS flat washer

Important—measure before starting!

Measure from the center of the wheel up to the bottom edge of the wheel opening

LF _____ RF _____

LR _____ RR _____

Step 2 Note

The nut for the track bar bolt at the axle is welded in place inside the factory mount.

INSTALLATION INSTRUCTIONS

1. Park the vehicle on a clean, flat surface. Block the rear wheels for safety.

» FRONT INSTALLATION

2. Locate and remove the bolt mounting the front track bar to the passenger's side of the front axle. **Figure 1** Save bolt.



Figure 1

3. Raise the front of the vehicle with a hydraulic jack. Support the vehicle with jack stands just behind each of the lower control arm pockets.
4. Remove the wheels.
5. Disconnect the sway bar links from the axle mounts. **Figure 2** Save hardware.



Figure 2

6. Support the axle with a hydraulic jack. Remove the front shocks. Discard shocks and hardware.
7. Lower the axle and remove the factory coil springs. Leave the upper and lower rubber isolators/mounts in place on the vehicle.
8. Remove the factory rubber bump stops from the bump stop retainers on each frame rail. Depending on the condition of the bump stops they normally can be removed with a pair of channel lock pliers and/or a flat blade screw driver. **Figure 3** Save bump stops.



Figure 3

9. Remove the bump stop retainers from the frame rails by removing the two mounting bolts. **Figure 4** Save the retainers and discard the hardware.

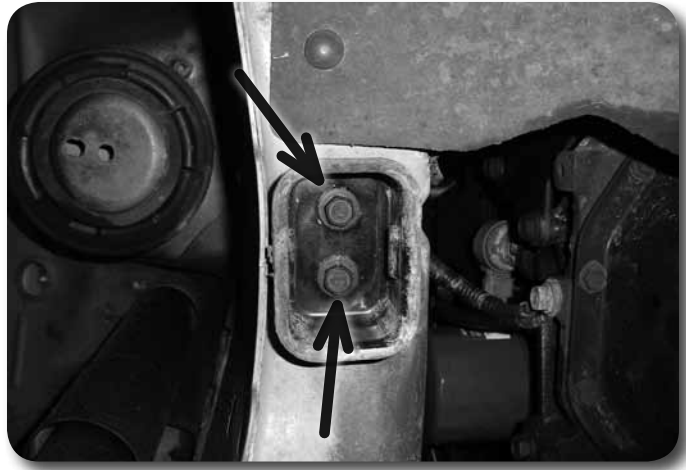

Figure 4

10. Remove the bolt mounting the track bar to the driver's side frame mount. **Figure 3** Save hardware. The track bar will not be reused.
11. Loosen, but do not remove the 4 lower control arm bolts. **Figure 5**



Figure 5

12. Working on one side of the vehicle at a time, remove the lower control arm from the vehicle. Install the new control arm assembly in the frame and axle mounts with the factory hardware with the bend down and closest to the axle **Figure 6**. At the frame end, install a provided 1/8" spacer washer on each side of the control arm end between the bushing sleeve and the bracket **Figure 7A**. On the axle end, install a 1/4" spacer washer on each side of the control arm end **Figure 7B**. Leave hardware loose.

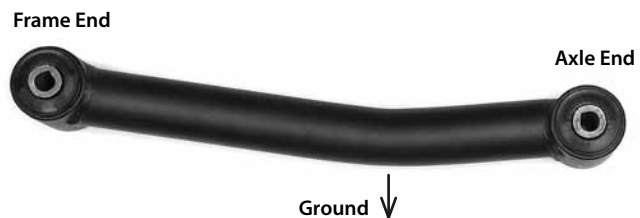

Figure 6

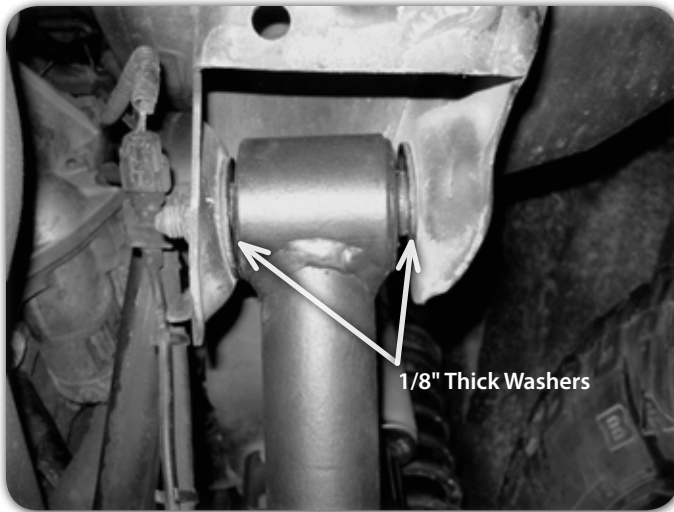

Figure 7A

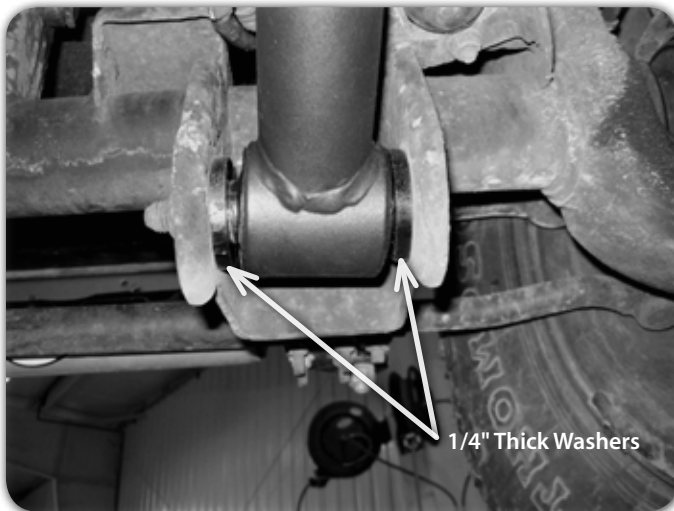

Figure 7B

13. Repeat lower control arm installation on the other side of the vehicle.
14. Locate the new rectangular front bump stop extensions. Reinstall the factory bump stop retainers on the frame rails with the new extensions and 8mm x 100mm bolts with 5/16" washers. **Figure 8** Use Loctite on the bolt threads and torque to 20 ft-lbs.

Step 14 Note

Hardware for the front bump stop installation is located in hardware pack #725



Figure 8

Step 15 Note

Tip for installing bump stops:
Position the rubber bump stops
in the retainer and use the jack to
compress the axle against the bump
stop to push them into place.

15. Liberally grease the mounting surfaces of the factory rubber bump stops and reinstall into the relocated retainers.
16. Locate and install the new front coil springs. **Figure 9** They are symmetric so there is not a specific top or bottom. Install the coils in the axle mount so that the end of the coil seats against the stop in the mount. Pushing the upper end of the coil into the upper isolator. Raise the axle until the springs are seated properly.



Figure 9

Step 17 Note

All shock mount hardware is
included in the individual shock
containers.

17. Install the new provided front shocks. Attach the shocks to the upper mount with the provided stem bushings and washers. Fasten with a 3/8" nut and tighten until the bushings begin to swell. Install a 3/8" jam nut (thin) and tighten it against the first nut. Attach the preinstalled bar pin at the axle end of the shock to the original mount with the provided 5/16" x 1-1/4" bolts, nuts and washer. Torque 5/16" hardware to 20 ft-lbs.
18. Reattach the factory sway bar links to the axle mounts with the original hardware. Torque bolts to 55 ft-lbs.
19. Install the wheels and lower the vehicle to the ground. Torque lug nuts to 90-115 ft-lbs.
20. Bounce the front of the vehicle to settle the suspension. Check to see that the axle is visually centered under the vehicle.

21. Locate the new adjustable track bar, track bar bushings and sleeves (0.750 x 0.134 x 1.575). Grease and install the bushings and sleeves in each end of the track bar. Adjust the track bar to 32-5/8" center-to-center. This is just a good starting point, the track bar may need to be adjusted more once in the vehicle.
22. Install the fixed end of the track bar in the passenger's side axle mount so the bend in the bar is toward the floor. **Figure 10** Loosely fasten the track bar in place with a 12mm x 70mm bolt and 1/2" SAE washer into the factory welded nut.



Figure 10

23. Install the adjustable end of the track bar into the driver's side frame bracket. If the hole in the bar is close to aligning with the hole in the bracket have an assistant turn the steering wheel slightly to help align the hole. If the hole is off more than half a hole width, double check that the axle is centered under the vehicle and adjust the track bar accordingly. Fasten the track bar to the frame mount with a 12mm x 70mm bolt, nut and 1/2" SAE washers. Torque the 12mm bolts at the axle and frame to 70 ft-lbs.
24. Lock off the jam nut on the track bar securely.
25. Torque the 4 lower control arm bolts to 115 ft-lbs.
26. Check all hardware for proper torque.

Step 21 Note

The provided track bar bushings are made from a high durometer polyurethane. It may be necessary to use a bench vice to install the bushings and sleeves into the track bar ends.

Step 22 Note

Applying a small amount of grease to the faces of the bushings will making installation into the brackets easier. Hardware for the front track bar installation is located in hardware pack #919.

» REAR INSTALLATION

1. Block the front wheels for safety. Raise the rear of the vehicle and support with jack stands just ahead of the lower control arm pockets.
2. Remove the wheels.
3. Disconnect the rear brake line from the driver's side of the upper control arm. **Figure 11** Save hardware.
4. Disconnect the parking bracket cable brackets from the driver's and passenger's side of the upper control arm. **Figure 11** Hardware will not be reused.

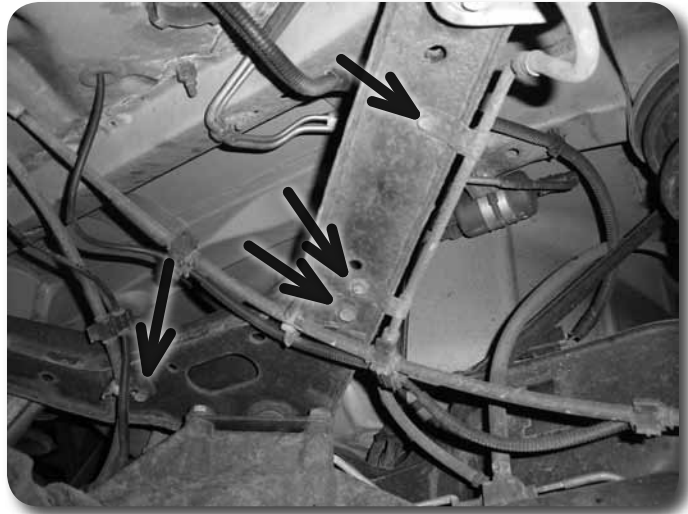

Figure 11

5. Using a large pair of pliers, squeeze the plastic insert in the parking brake cable brackets and remove the bracket from the cable. Figure 12A, 12B Remove the plastic "C" from the cable.

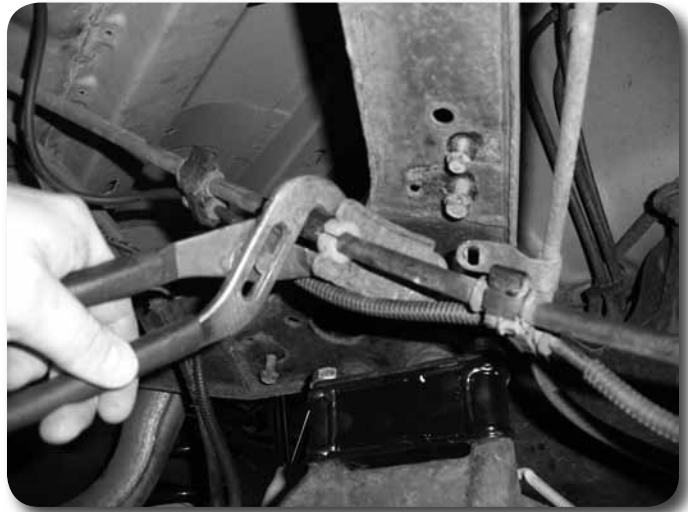

Figure 12A



Figure 12B

6. Support the axle with a hydraulic jack. Remove the rear shocks. Save hardware.
7. Disconnect the rear sway bar links from the sway bar and the frame. **Figure 13** Save the upper hardware, the lower hardware and links will not be reused.

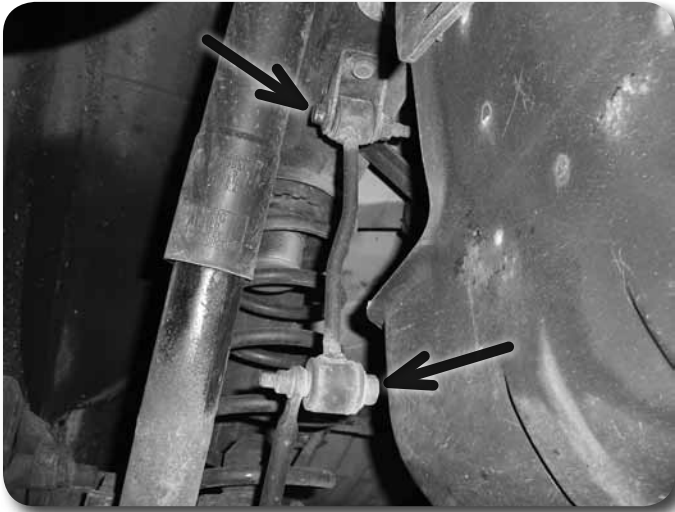

Figure 13

8. Lower the axle and remove the factory coil springs. Leave the upper and lower spring isolators in the vehicle.
9. Remove the lower axle bump stops from the center of the coil mounts. Save bump stops.
10. Locate the center hole in the upper coil mount. Using the provided 3/8" self-tapping bolt, tap the driver's and passenger's side coil mount holes. **Figure 14A** After they have been tapped, attach the provided bump stop extension with the new 3/8" x 2-1/2" bolts and washers. **Figure 14B** Use Loctite on the bolt threads and torque bolt to 20 ft-lbs.
11. Locate the factory upper control arm end mount on the top of the differential. **Figure 15** Remove the three bolts mounting the control arm to the differential. Remove the front, center bolt first followed by the two side bolt (removed simultaneously). Once the side bolts are removed from the differential the control arm end can be rotated to allow the bolts to be removed.

Step 10 Note

Fasteners for the rear bump stop extension are located in hardware pack #439.



Figure 14A



Figure 14B

Step 12 Note

Fasteners for the rear UCA spacer are located in hardware pack #725.

12. Install 3 new 14mm x 80mm bolts and washers into the holes of the upper control arm end. Apply Loctite to the 14mm bolt threads. Install the provided control arm spacer on the bolts and align the bolts to the holes in the differential. **Figure 16** Tighten the bolts and torque to approximately 100 ft-lbs.

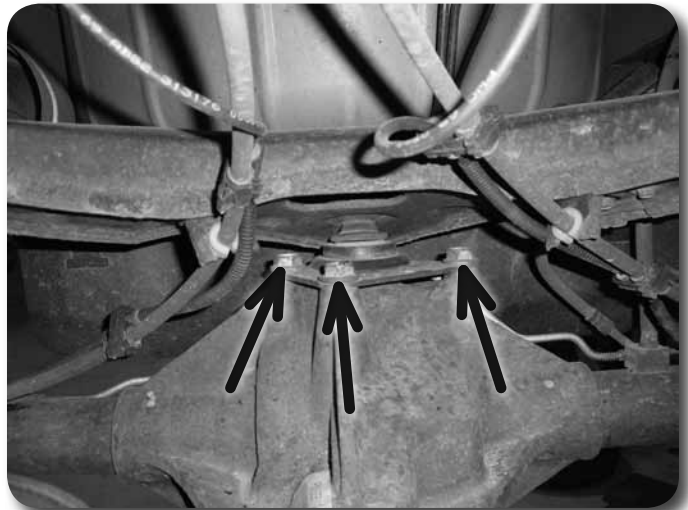

Figure 15



Figure 16

13. Liberally grease the mounting surfaces of the factory rear rubber bump stops and install them into the new rear coils springs before installing the new spring in the the vehicle. Install the spring in the upper mount first and slide onto the axle mount. Be sure the coil is seated properly in the axle mount. Install the bump stop into the original retainer on the axle. A flat pry bar can be used if necessary to fit the bump stop in place. **Figure 17**



Figure 17

14. Locate the new rear shocks and install the provided bushings and sleeves in each end. Attach the BODY end of the shock to the axle mount and fasten with the factory bolt. Install the ROD end of the shock in the upper mount along with 2 1/2" washer placed on each side of the bushing. **Figure 18** Fasten with the factory bolt. Torque the shock bolts to 75 ft-lbs.

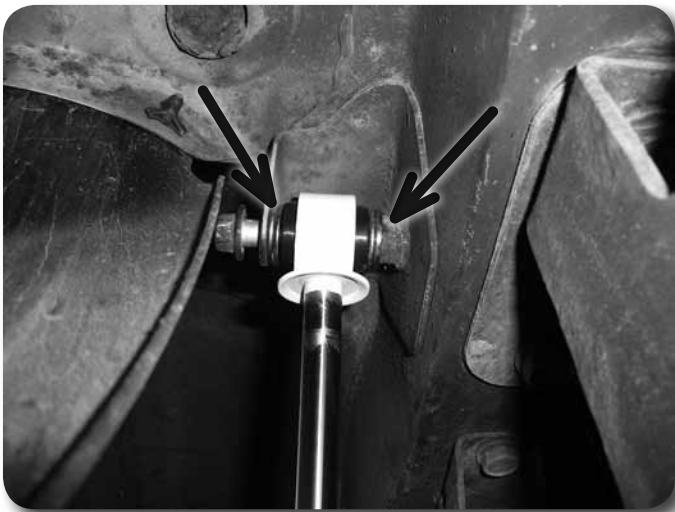

Figure 18

15. Locate the new rear sway bar links and hourglass bushings. Install the bushings and a 0.625 x 0.109 x 1.375 (small ID) sleeve in one end and a 0.625 x 0.075 x 1.375 (large ID) sleeve in the other end of each sway bar link. Attach the end of the links with the large ID sleeves to the frame mounts with the factory hardware. Attach the end of the links with the small ID sleeves to the sway bar with the provided 10mm x 65mm bolts, nuts and washers. **Figure 19** Torque the upper bolts to 55 ft and the lower bolts to 35 ft-lbs.

Step 14 Note

All shock mount hardware is included in the individual shock containers.

Step 15 Note

Hardware for the rear sway bar link installation is located in hardware pack #725

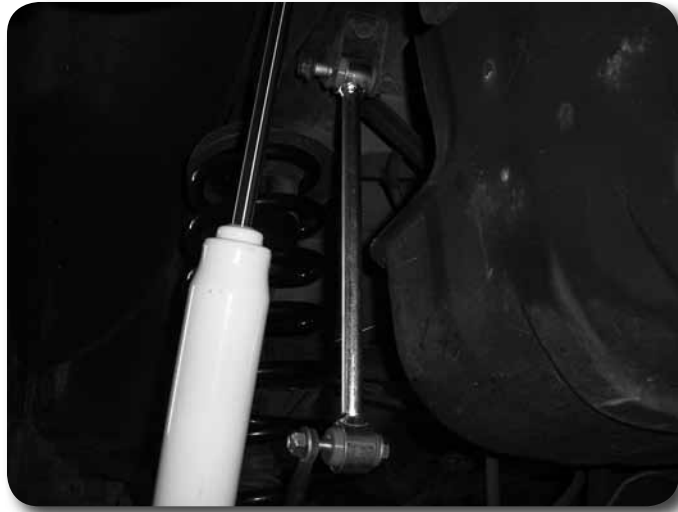

Figure 19

16. Reattach the brake line to the driver's side of the upper control arm using the original hardware. In some cases it may be necessary to slightly bend the end of the hardline at the control arm to gain slack for the rubber line running from the control arm to the axle. **Figure 20** Only enough slack is needed to hook up the line to the upper control arm.



Figure 20

17. Install the wheels and lower the vehicle to the ground. Torque the lug nuts to 90-115 ft-lbs.
18. Check all hardware for proper torque.

»» **TRANSFER CASE DROP**

1. Support the transfer case with a hydraulic jack.
2. Locate and remove the 8 (4 per side) transmission crossmember mounting bolts. **Figure 21**
3. Slowly lower the jack until there is about 1" of space between the crossmember and the frame. Install the provided spacers with the hollow side up at each of the 8 hole locations. Fasten the crossmember/spacers to the frame with the provided 10mm x 100mm/washers (2 outside holes on each side) and 10mm x 140mm/washers (2 inside holes on each side). Apply Loctite to the bolt threads before installing. When all of the bolts are started torque all 8 bolts to 45 ft-lbs.

Step 3 Note

Hardware for the transfer case drop installation is located in hardware pack #726

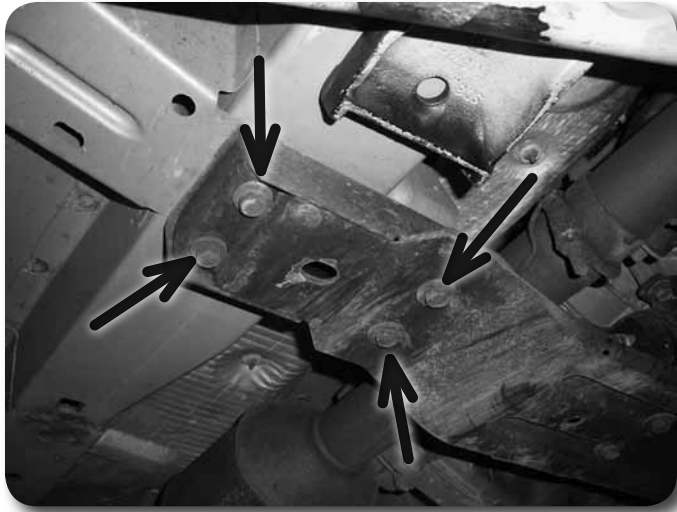

Figure 21

» POST-INSTALLATION

1. Check all hardware after 500 miles for proper torque.
2. Grease the 4 grease fittings located on each end of the new front lower control arms. Grease these points during regularly schedule maintenance intervals.
3. The steering wheel may be off-center after the installation. The position of the steering wheel is corrected by loosening the clamps on the drag link (runs from the pitman arm on the steering box to the passenger's side steering knuckle) and rotating it to shorten or lengthen, depending on which way the wheel needs to be adjusted.

Step 3 Note

Some installers with a novice skill level or lower may wish to have an experienced mechanic make these steering wheel adjustments.

Post-Installation Warnings

1. Check all fasteners for proper torque. Check to ensure for adequate clearance between all rotating, mobile, fixed, and heated members. Verify clearance between exhaust and brake lines, fuel lines, fuel tank, floor boards and wiring harness. Check steering gear for clearance. Test and inspect brake system.
2. Perform steering sweep to ensure front brake hoses have adequate slack and do not contact any rotating, mobile or heated members. Inspect rear brake hoses at full extension for adequate slack. Failure to perform hose check/ replacement may result in component failure.
3. Perform head light check and adjustment.
4. Re-torque all fasteners after 500 miles. Always inspect fasteners and components during routine servicing.