



#J2200 Installation Instructions 1997-2006 Jeep TJ 1.75" Coil Spacer Lift

Read and understand all instructions and warnings prior to installation of product and operation of vehicle.

Zone Offroad Products recommends this system be installed by a professional technician. In addition to these instructions, professional knowledge of disassembly/ reassembly procedures and post installation checks must be known. Minimum tool requirements include the following: Assorted metric and standard wrenches, hammer, hydraulic floor jack and a set of jack stands. See the "Special Tools Required" section for additional tools needed to complete this installation properly and safely.

» PRODUCT SAFETY WARNING

Certain Zone Offroad Products are intended to improve off-road performance. Modifying your vehicle for off-road use may result in the vehicle handling differently than a factory equipped vehicle. Extreme care must be used to prevent loss of control or vehicle roll-over. Failure to drive your modified vehicle safely may result in serious injury or death. Zone Offroad Products does not recommend the combined use of suspension lifts, body lifts, or other lifting devices.

You should never operate your modified vehicle under the influence of alcohol or drugs. Always drive your modified vehicle at reduced speeds to ensure your ability to control your vehicle under all driving conditions. Always wear your seat belt.

» TECHNICAL SUPPORT

Live Chat provides instant communication with Zone tech support. Anyone can access live chat through a link on www.zoneoffroad.com.

www.zoneoffroad.com may have additional information about this product including the latest instructions, videos, photos, etc.

Send an e-mail to tech@zoneoffroad.com detailing your issue for a quick response.

888.998.ZONE Call to speak directly with Zone tech support.

» PRE-INSTALLATION NOTES

1. Special literature required: OE Service Manual for model/year of vehicle. Refer to manual for proper disassembly/reassembly procedures of OE and related components.
2. Adhere to recommendations when replacement fasteners, retainers and keepers are called out in the OE manual.
3. Larger rim and tire combinations may increase leverage on suspension, steering, and related components. When selecting combinations larger than OE, consider the additional stress you could be inducing on the OE and related components.
4. Post suspension system vehicles may experience drive line vibrations. Angles may require tuning, slider on shaft may require replacement, shafts may need to be lengthened or trued, and U-joints may need to be replaced.
5. Secure and properly block vehicle prior to installation of Zone Offroad Products components. Always wear safety glasses when using power tools.
6. If installation is to be performed without a hoist, Zone Offroad Products recommends rear alterations first.
7. Due to payload options and initial ride height variances, the amount of lift is a base figure. Final ride height dimensions may vary in accordance to original vehicle attitude. Always measure the attitude prior to beginning installation.

Difficulty Level

easy 1 **2** 3 4 5 difficult

Estimated installation hours: 2-3

Special Tools Required

T-50 Torx socket

Small Pickle Fork

Tire/Wheel Fitment

32" x 11.50" tire/15x8, 3.5" B.S. wheel

Kit Contents

Qty	Part
4	2" Coil Spring Spacer
4	Bump Stop Extension
4	10mm x 80mm Bolt

INSTALLATION INSTRUCTIONS

1. Park the vehicle on an appropriate work surface. Ensure that the vehicle is in park for automatic transmission or in first gear for manual transmissions and the parking brake is applied. Block the wheels for added safety.

» FRONT INSTALLATION

2. Remove the bolt mounting the front track bar to the passenger's side of the axle (Figure 1). Save track bar bolt and nut tab. Allow the track bar to hang free.

Step 2 Note

The track bar bolt may require a T-50 Torx socket on early models.

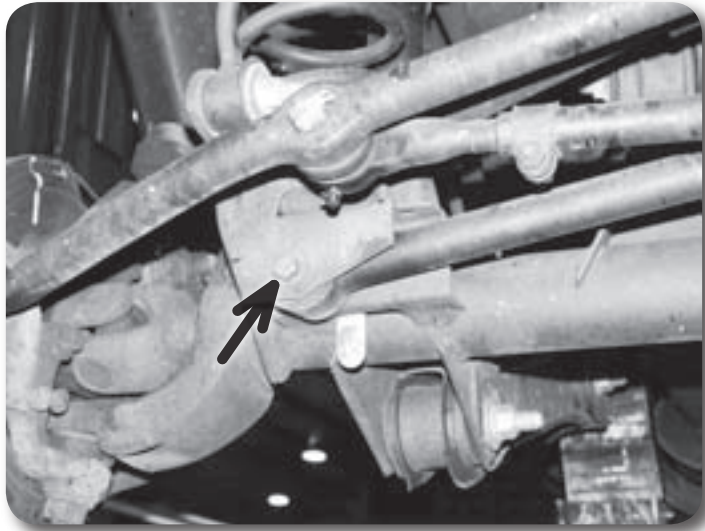

Figure 1

3. Raise the front of vehicle with a hydraulic jack and place jack stands under the frame rails, just behind the lower control arm pockets.
4. Remove the wheels.
5. 1997 model TJ only: Mark the position of the alignment cam adjusters located at the end of each front lower control arm at the axle (Figure 2).

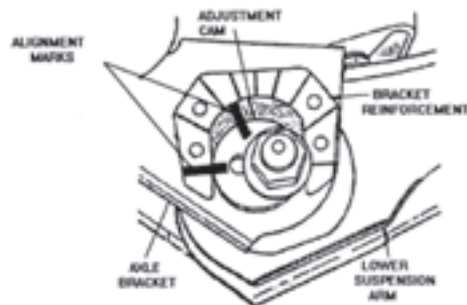

Figure 2

6. Support the front axle with a hydraulic jack. Remove the shocks. Save the lower shock hardware.
7. Remove the upper mounting nut from the sway bar links (Figure 3). Disconnect the links from the sway bar with a pickle fork to release the tapered seat.

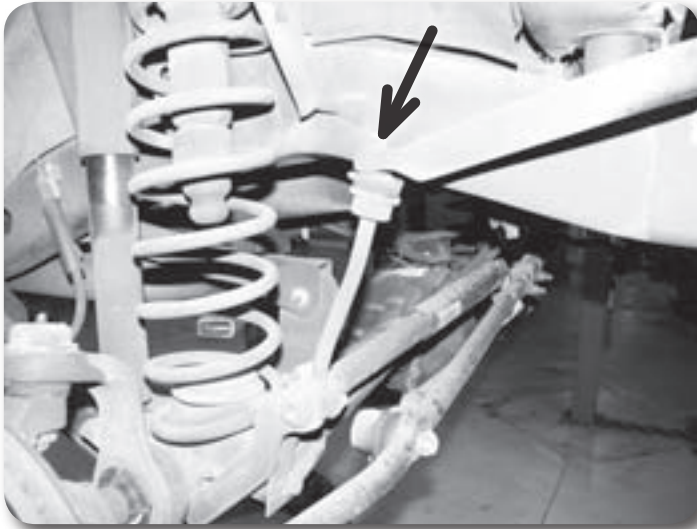

Figure 3

8. Remove the cotter pin and castellated nut from the drag link end at the pitman arm (Figure 4). Thread the nut back on a couple of turns. Strike the pitman arm near the drag link end to release the tapered seat. Take care not to damage the end. Remove the nut and the drag link from the pitman arm. Save hardware.

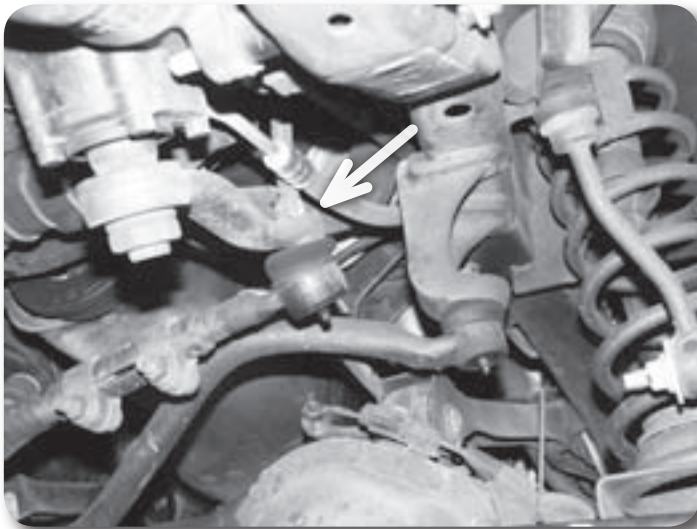

Figure 4

9. Remove the driver's side coil spring retainer clip located on the back side of the axle coil seat. Save clip and bolt.
10. Loosen the driver's and passenger's side lower control arm bolts at the axle. Completely remove the passenger's side bolt and leave the driver's side in place. This should allow the axle to lower enough to remove and install the coil springs.
11. Lower the axle with the hydraulic jack and remove the coil springs. Take care not to over extend the brake lines.

12. Remove the factory rubber bump stop from the upper coil mount (Figure 5). Large pliers can be used to pull it out. Remove the factory bump stop retainer cup by removing the bolt from the center.

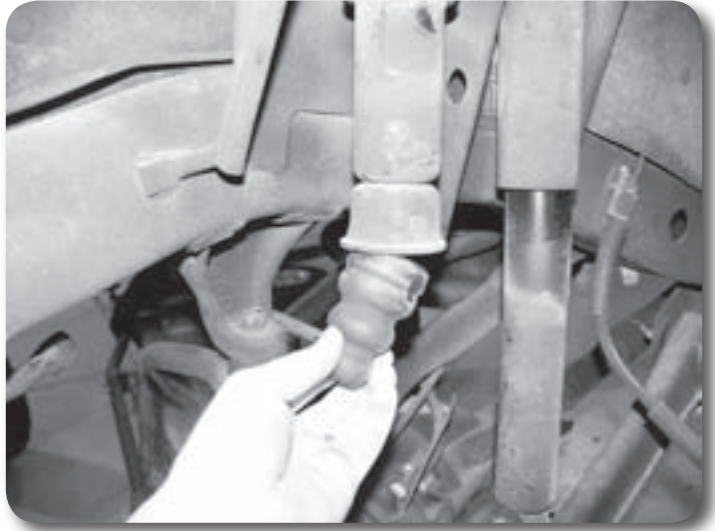

Figure 5

Step 13 Note

The small “lip” on the coil spacer should point down when it is installed.

13. Slide the new coil spring spacer onto the upper coil mount. Leave the factory coil spacer in place, the new mount will be positioned below it. While holding the new spacer in place, install the provided bump stop extension between the factory retainer cup and the coil mount. Fasten the extension and retainer cup with a provided 10mm x 80mm bolt. (Figure 6) Torque bolt to 30 ft-lbs.



Figure 6

14. With the factory retainer cup in place, reinstall the factory rubber bump stop.
15. Reinstall the factory coil springs and rotate the ends so that they seat properly in the axle mounts.
16. Raise the axle until the coils seat against the new coil spacers and have a slight amount of pressure on them. Reinstall the driver’s side coil retainer and torque to 20 ft-lbs.
17. Reattach the passenger’s side lower control arm bolt/nut/washers. Snug the bolt but do not tighten completely. Both lower control arm bolts will be tightened with the weight of the vehicle on the suspension.

Step 14 Note

A small amount of grease on the bump stop will make installation easier.

18. Install the new shocks with the provided upper bushings/hardware. Leave the upper nut loose.
19. Attach the shock to the axle with the original shock hardware. Torque bolts to 20 ft-lbs. Go back and tighten the upper shock stem nut until the stem bushings begin to swell. Install the thin jam nut on the stem and tighten it against the first nut.
20. Reattach the drag link to the pitman arm with the original castellated nut. Torque the nut to 60 ft-lbs. Align the cotter pin hole with the slots in the nut and install the cotter pin. Never loosen the nut to align the cotter pin, only tighten. If the original cotter pin is damaged, replace it with a new one.
21. Install the wheels and torque the lug nuts to the manufacturer's specs. See vehicle owner's manual.
22. Remove the jack stands and lower the vehicle to the ground.
23. Bounce the front of the vehicle to settle the suspension.
24. Attach the sway bar links to the sway bar with the original nuts. Torque nuts to 25 ft-lbs.
25. Reconnect the front track bar to the axle mount with the original hardware. Torque bolt to 50 ft-lbs. Note: To aid in aligning the track bar hole have an assistant turn the steering wheel to shift the trackbar in the correct direction.
26. Torque the lower control arm bolts to 85 ft-lbs. Note: If working on a 97 model, be sure to align the marks made at the beginning of the installation before tightening the bolts.
27. Check all hardware for proper torque.

» REAR INSTALLATION

1. Disconnect the rear track bar from the passenger's side frame mount (Figure 7). Save hardware.

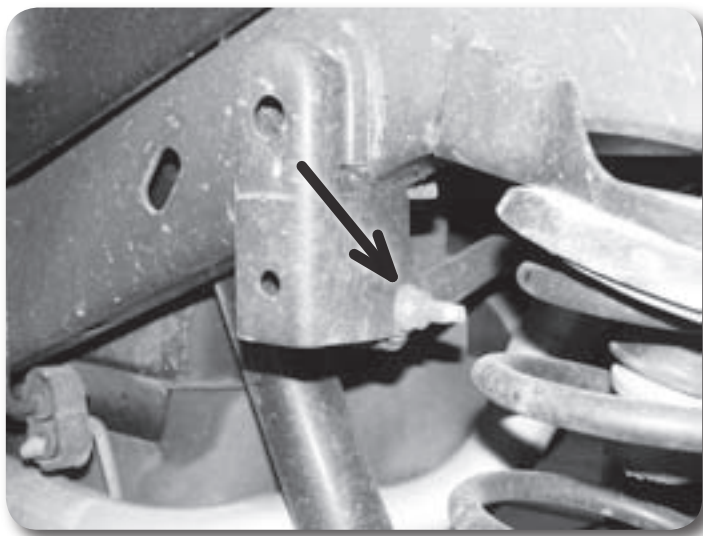

Figure 7

2. Raise the rear of vehicle with a hydraulic jack and place jack stands under the frame rails, just ahead of the lower control arm pockets.
3. Remove the wheels.
4. Support the rear axle with a hydraulic jack. Remove the shocks. Save all shock hardware.
5. Disconnect the sway bar links from the sway bar (Figure 8). Save hardware.

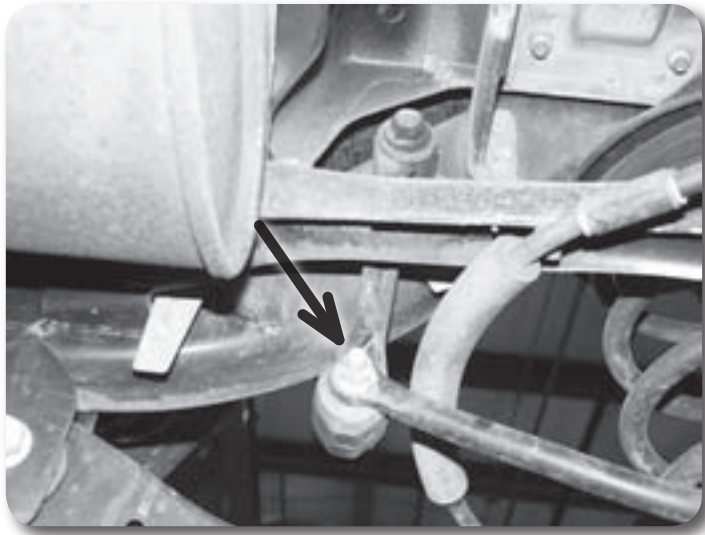

Figure 8

Step 9 Note

A small amount of grease on the bump stop will make installation easier.

Post-Installation Warnings

1. Check all fasteners for proper torque. Check to ensure for adequate clearance between all rotating, mobile, fixed, and heated members. Verify clearance between exhaust and brake lines, fuel lines, fuel tank, floor boards and wiring harness. Check steering gear for clearance. Test and inspect brake system.
2. Perform steering sweep to ensure front brake hoses have adequate slack and do not contact any rotating, mobile or heated members. Inspect rear brake hoses at full extension for adequate slack. Failure to perform hose check/ replacement may result in component failure.
3. Perform head light check and adjustment.
4. Re-torque all fasteners after 500 miles. Always inspect fasteners and components during routine servicing.

6. Lower the axle with the hydraulic jack and remove the coil springs.
7. Remove the factory rubber bump stop from the upper coil mount. Large pliers can be used to pull it out. Remove the factory bump stop retainer cup by removing the bolt from the center.
8. Slide the new coil spring spacer onto the upper coil mount. Leave the factory coil spacer in place, the new mount will be positioned below it. Will holding the new spacer in place, install the provided bump stop extension between the factory retainer cup and the coil mount. Fasten the extension and retainer cup with a provided 10mm x 80mm bolt. Torque bolt to 30 ft-lbs.
9. With the factory retainer cup in place, reinstall the factory rubber bump stop.
10. Reinstall the factory coil springs in the upper and lower spring seats.
11. Lightly grease and install the provided hourglass bushing and steel sleeve in the rear shock eyes. Note: One end will have a bar pin preinstalled.
12. Attach the new shocks to the frame with the original hardware. Torque bolts to 20 ft-lbs.
13. Raise the rear axle until the shocks can be fastened to the axle mounts with the original hardware. Torque bolts to 55 ft-lbs.
14. Reattach the sway bar links to the sway bar with the original hardware. Torque bolts to 30 ft-lbs.
15. Install the wheels and torque the lug nuts to the manufacturer's specs. See vehicle owner's manual.
16. Remove the jack stands and lower the vehicle to the ground.
17. Bounce the rear of the vehicle to settle the suspension.
18. Reattach the rear track bar to the passenger's side frame mount with the original hardware. Have an assistant push on the side of the body to help align the track bar in the bracket. Torque bolt to 70 ft-lbs.
19. Check all hardware for proper torque.

» POST-INSTALLATION

1. A front end alignment is required to adjust toe-in setting as well as straighten the steering wheel. Caster can be adjusted on 97 models using the factory alignment cams bolts. Zone Suspension offers replacement cam bolt kits for all 97-06 models, part #J5311.