



# INSTALLATION INSTRUCTIONS

**Product: Flex Connect Sway Bar Disconnect System™**

**Part Number: PAC2113,**

**Applications: Wrangler TJ, 1997-2006 with 2-4.5" Lift**

**Cherokee XJ 1984-2001 with 4-6" Lift**

**Grand Cherokee ZJ 1993-1998 4.5"-6" Lift**

517-278-1226 • jks@ridefox.com • www.jksmfg.com  
491 W. Garfield Avenue, Coldwater, MI 49036

## Welcome

CONGRATULATIONS on purchasing the Flex Connect Sway Bar Link System from JKS Manufacturing. We are committed to providing you with the best products available and your satisfaction is our first priority.

PLEASE READ these Installation Instructions carefully, and save them for future reference, as they contain important installation and maintenance information.

## Tools Required

- Metric/Standard Socket Wrench Set
- Metric Allen Socket Set
- 5/16"-18 tap
- Grease Gun with Zerk Fitting Coupler
- Non petroleum based grease

PAC2113		
	Description	Qty
A	Flex Connect Link	1
B	Quicker Disconnect Link	1
C	Sway Bar Clevis Bracket	2
D	10mm X 35mm socket head bolt and nut	2
E	10mm X 55mm socket head bolt and nut	4
F	Poly Spacer	2
G	Stainless Post and nut	2
	Click Pin	2
	Storage Post	2
	5/16"-18 Socket Head Bolt	2
	5/16"-18 Nylock Nut	2

## Parts

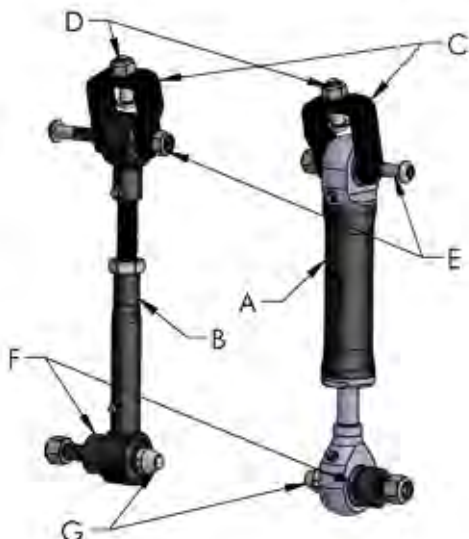

## WARNING

### Higher Rollover Risk



Modifying your Jeep® to improve off-road performance may result in vehicle handling different than as factory equipped, including increased ride-height and/or chassis articulation; reduced lateral stability and higher risk of roll-over or other accident. Also, owner's choice of larger tire and wheel combinations may require additional braking force or increased stopping distances.

#### To reduce risk of serious injury and accident:

- Choose modifications that balance your actual highway & off-road use.
- Avoid sharp turns, abrupt maneuvers or steep side-cambers.
- Avoid other maneuvering conditions which may cause the vehicle to trip, roll, lose traction or compromise your ability to safely brake in an emergency.
- Routinely inspect your vehicle components for unusual wear or off-road damage. Repair or Replace any unserviceable components before use.
- Acquaint any other drivers with your vehicle modifications and handling.
- Always wear seat belts and/or appropriate off-road restraints, reduce your speed, Tread Lightly®.

## Important

*Designed for use the factory sway bar. Fitment and performance with aftermarket sway bars is up to the installer.*

*Flex Connect Link measures 9-3/4" eye-eye with the clevis bracket. Due to variations in shock length and bump stops with lift systems, it is up to the installer to verify fitment. If the links being replaced measure longer than 9-3/4" eye-eye, additional modifications may be required to avoid sway bar inversion in full droop conditions. Check link position at full suspension droop and compression before driving. Some vehicles may require extended front brake hoses or other modifications to compensate for additional suspension travel.*

## Installation

- ❑ 1. REMOVE ORIGINAL EQUIPMENT (OE) SWAYBAR LINKS
  - Remove front swaybar drop links and mounting hardware per the factory service manual instructions for your vehicle. **HINT:** If difficult to remove, use special factory removal tool PN MB991113 (Miller Special Tools, 800-801-5420) or similar tie rod end removal tool.



## ❑ 2. INSTALL UPPER U-STRAPS

- Mount U-Strap (A) on top of swaybar with offset leg positioned inboard.

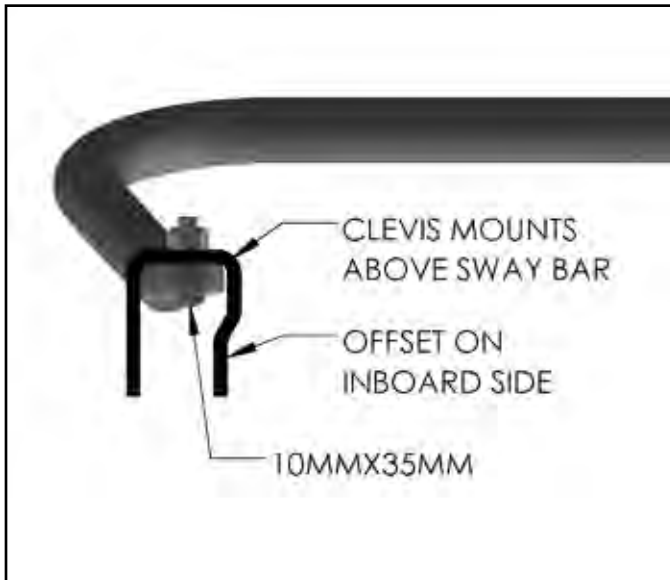

- Insert 10mm x 35mm Button Head Bolt and flat washer - only if required - upward through swaybar and U-Strap. Secure with 10mm Nylock Nut.

**IMPORTANT: Flat Washers are supplied for use with 1984-01 Cherokee XJ and 1993-98 Grand Cherokee ZJ models ONLY. Do NOT use Flat Washer on Wrangler TJ models.**



- Tighten 10mm Nylock Nut to 40 ft-lb.

## ❑ 3. AXLE MOUNTING POSTS

- Remove the nut and insert the Stainless Steel Posts into the lower swaybar link holes on the front axle. Position posts with tapered ends pointing inboard, ensuring small Click Pin holes are horizontal or parallel with the ground.
- Install 1/2" Nylock Nut on the outboard side of lower swaybar link brackets and tighten to 65 ft-lb. using a torque wrench.



**HINT: A small Philips head screwdriver or punch inserted into the Click Pin hole will enable you to prevent the tapered Stainless Steel Posts from rotating when tightening the Nylock nut.**

## ❑ 4. INSTALL QUICKER DISCONNECT LINK

- Adjust the passenger side link to be the same length as the flex connect link (9-3/4") and lock off the jam nut. Keep the eyes in line with each other.

**IMPORTANT: Flex eyes must remain parallel with each other when the jam nut is tightened.**

- Install the bushing sleeve to the upper end of the quicker disconnect link.
- Insert the upper end of Quicker Disconnect into the passenger side clevis mount and install from the outside in, the 10mm x 55mm Button Head Bolt. Fasten with the nylock nut. Tighten to 40 ft-lb.



- Slide the lower end of the Quicker Disconnect onto the tapered stainless steel post.

## ❑ 5. INSTALL FLEX CONNECT LINK

- Install the sleeve in the body side of the Flex Connect. With the grease fittings facing forward attach the flex connect to the clevis mount with the 10mm x 55mm button head bolt and nylock nut similar to the passenger side.
- Slide the Flex Connect onto the axle post.

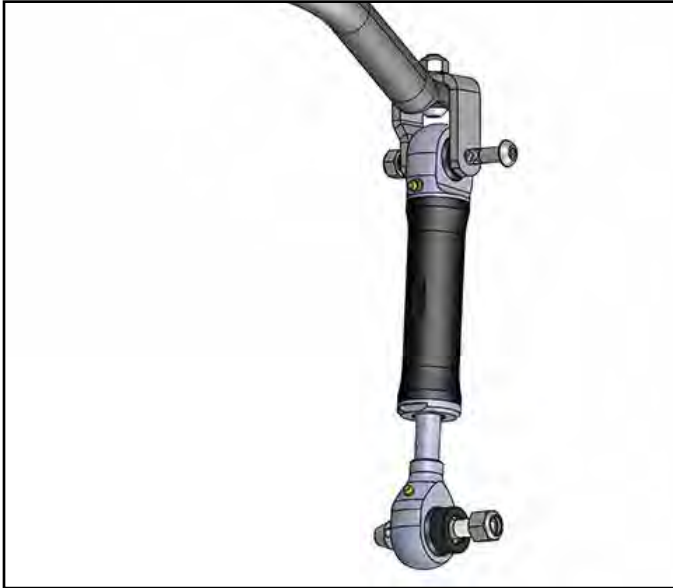

- Insert Click Pins as illustrated to secure.

### CORRECT

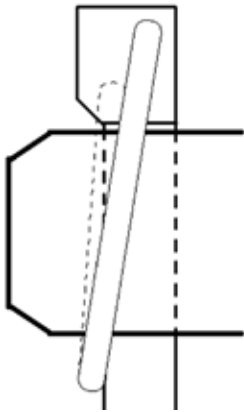

### WRONG

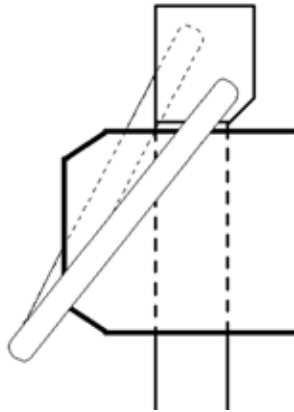

**IMPORTANT:** When properly installed, the ring on the Click Pin will “snap” against the shaft of pin. When installed backwards, the ring does not fit snugly against shaft.

## ❑ 6. INSTALL STORAGE PINS

The supplied Storage Pins can only be used on Wrangler TJ models, or Cherokee XJ / Grand Cherokee ZJ models equipped with OE front skid plate.

**IMPORTANT:** Storage Pins must be mounted in a location that will allow FULL suspension and steering travel WITHOUT tire interference.

## TJ Models

- Locate mounting point for Storage Pins on chassis that allows Disconnect to reach it without adjustment. Using a size “F” drill bit, drill a hole in the outboard side of each chassis rail and tap with 5/16” x 18TPI tap.
- Install Storage Pins using the supplied 5/16” x 1-1/2” NC Allen Bolts.

## XJ / ZJ Models (with OE Front Skid Plate)

- Locate mounting point for Storage Pins on OE Front Skid Plate that allows Disconnect to reach it without adjustment. Drill a 5/16” hole in outboard sides of skid plate.
- Install Storage Pins using the supplied 5/16” x 1-1/2” NC Allen Bolts and 5/16” Nylock Nuts.

## XJ / ZJ Models (without OE Front Skid Plate)

- DO NOT INSTALL supplied Storage Pins on vehicle. Instead, swaybar and Quicker Disconnects may be secured to chassis with JKS lanyard kit 2039 or other means.

## ❑ 6. FINAL INSTALLATION STEPS

- Torque all lower mounting studs to 65 ft-lbs.
- Lubricate all grease fittings on the link eyes immediately after installation using a grease gun and non-petroleum based grease.

## Troubleshooting

If swaybar does not rotate freely, remove from vehicle, clean and apply rubber lubricant to chassis-mounted bushings, and reinstall.

Contact between Quicker Disconnect Clevis Mount and vehicle chassis on Wrangler TJ models usually indicates a misaligned swaybar caused by a front axle that is not centered. Take consistent measurements on each side of vehicle to confirm misalignment, and install JKS Adjustable Trackbar. JKS sway bar clamps part # 2038 can also be installed to cure this problem.

## Maintenance

It is important to lubricate the flex eyes frequently for the first three (3) months after installation to evacuate contaminants that may build up during break-in period.

After break-in period, the flex eyes should be lubricated regularly as part of vehicle maintenance schedule.

Regular cleaning with pressurized water is recommended to maximize ease of operation and reliability. Always lubricate afterwards to evacuate any moisture

©2018 JKS Manufacturing, Inc  
Revision Date 07/23/2018

## Flex Connect Rebuild

The internal components of the Flex Connect are sealed and designed for maintenance free long term performance. These instructions are provided as a reference for the steps required to swap springs. The Flex Connect Performance Spring Kit is sold separately as part number 2100.

### ❑ 1. FLEX CONNECT DISASSEMBLY

These instructions are written with the assumption the customer has the assembly wrenches included in the Performance Spring Kit. If not, 2 crescent wrenches with jaw openings up to 1-1/2" can be used.

- Hold the body of the Flex Connect across the flats and loosen the Flex Connect body as shown in the Figure.

*Note: A 3/8" ratchet can be inserted into the square hole in the wrench if additional leverage is required.*



*Note: If using a vice, put the cap in the vice jaws and use the provided wrench on the body to prevent the vice from binding on the threads.*

- With the cap unthreaded, slide the shaft assembly out of the body.

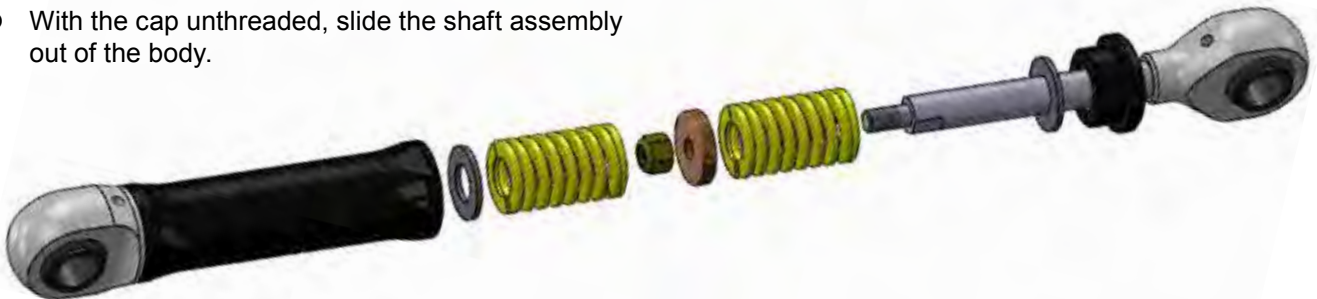

- Tip the Flex Connect body up and the spring followed by the washer will fall out of the body.
- To remove the spring from the shaft, hold the shaft across the flats next to the bronze bushing and remove the nut.

*Note: The wrench with the rounded opening is 1/2" across the flats for the rod and the other is 9/16" for the nut.*



- Slide the spring off of the shaft.

*Note: The spring washer goes on the side of the spring towards the cap.*

### ❑ 2. FLEX CONNECT ASSEMBLY

- Install the washer back into the body of the Flex Connect followed by the spring of your choosing.
- Install a matching spring onto the Flex Connect shaft followed by the bronze bushing and nut
- Torque the nut to 25 ft-lbs.

*IMPORTANT: Always install matching springs into the Flex Connect. Failure to do so will create different roll stiffness depending on the direction of roll and yield undesirable handling characteristics.*

- Apply grease to the bronze bushing if it was removed during disassembly
- Slide the Flex Connect shaft back into the housing and slide the cap down the shaft until the threads engage.
- Tighten the cap to approximately 25 ft-lbs.